

Quantum Information and Computation

Cambridge University Mathematical Tripos: Part II

4th May 2024

Contents

1	Mathematical background	3
1.1	Motivation	3
1.2	Benefits of quantum information and computation	3
1.3	Hilbert spaces	4
1.4	First postulate: quantum states	5
1.5	Second postulate: composite systems	6
1.6	Observables	6
1.7	Dirac notation for linear operators	6
1.8	Projection operators	7
1.9	Tensor products of linear maps	7
1.10	Third postulate: physical evolution of quantum systems	8
1.11	Partial inner products	8
1.12	Fourth postulate: quantum measurement	9
1.13	Complete and incomplete projective measurements	9
1.14	Extended Born rule	10
1.15	Standard measurement on multi-qubit systems	10
1.16	Reliably distinguishing states	11
2	Quantum states as information carriers	11
2.1	Using higher Hilbert spaces	11
2.2	No-cloning theorem	11
2.3	Distinguishing non-orthogonal states	13
2.4	No-signalling principle	14
2.5	The Bell basis	15
2.6	Superdense coding	15
2.7	Quantum gates	16
2.8	Quantum teleportation	17
3	Quantum cryptography	18
3.1	One-time pads	18
3.2	The BB84 protocol	19
4	Quantum computation	21
4.1	Classical computation	21
4.2	Classical complexity	21

4.3	Quantum circuits	22
4.4	Quantum oracles	22
4.5	Deutsch–Jozsa algorithm	23
4.6	Simon’s algorithm	24
4.7	Quantum Fourier transform	25
4.8	Efficient implementation of quantum Fourier transform	27
4.9	Grover’s algorithm	29
4.10	Grover’s algorithm for multiple items	31
4.11	NP problems	32
4.12	Shor’s algorithm	33

1 Mathematical background

1.1 Motivation

In classical computation, the elementary unit of information is the *bit*, which takes a value in $\{0, 1\}$. This gives the result of a single binary decision problem, where the zero and one correspond to different answers to the problem. Binary strings of length greater than one are used to provide more than 2 answers to a problem; if we have n bits, we can encode 2^n different messages.

Classical computation is understood to be the processing of information: taking an initial bit string and updating it by a prescribed sequence of steps. The steps are taken to be the action of local Boolean logic gates, such as conjunction, disjunction, or negation. At each step, a small number of bits in prescribed locations are edited.

Information in the real world must be tied to a physical representation. For example, bits in a processor are often represented by different voltages of specific components. Importantly, there is no information *without* representation. Performing a computation classically must therefore involve the evolution of a physical system over time, which is covered by the laws of classical physics.

However, nature does not abide by classical physics at subatomic levels, and we must use quantum mechanics to accurately model such behaviours. One such behaviour modelled by quantum mechanics is the superposition principle, that the corresponding quantum analog of the bit need not be in precisely one state. Quantum entanglement is the phenomenon where particles can be linked in such a way that their states can be manipulated even at a distance. Quantum measurement is probabilistic and alters the underlying system.

Quantum information and computation therefore exploits these features of quantum mechanics to address issues of information storage, communication, computation, and cryptography. The features of quantum mechanics seem to allow us benefits which are beyond the limits of classical information and computation, even in principle. Note that a quantum computer cannot perform any task that cannot in principle be performed classically. We only hope that quantum techniques allow a reduction in the complexity of certain algorithms.

1.2 Benefits of quantum information and computation

In complexity theory, we study the *hardness* of a certain computational task. One must consider the resources required for the task; which in classical computation are normally limited to time (measured in number of computational steps) and space (amount of memory required).

If an algorithm takes time bounded by a polynomial function in the input size n , we say the algorithm is *polynomial-time*. Otherwise, we say it is an *exponential-time* algorithm. Polynomial-time algorithms are typically taken to be computable in practice, but exponential-time algorithms are usually considered only computable in principle. Quantum mechanical techniques can provide polynomial-time algorithms that have only exponential-time classical versions. One example is Shor's integer factorisation algorithm.

Quantum states of physical systems can be used to encode information, such as spin states of electrons. There are certain tasks possible with such quantum states which are impossible in classical physics; one example is quantum teleportation.

There are also some technological issues with classical physics. Components of processors have become minified to atomic scale, and therefore they cannot be shrunk much further without dealing with the effects of quantum mechanics. Conversely, there are technological challenges with quantum

physics. Quantum systems are very fragile, and modern quantum computers typically require temperatures close to absolute zero to reduce noise.

Quantum supremacy refers to the hypothetical moment at which a programmable quantum computer can first solve a problem in practice that a classical computer cannot. At the time of writing, there is no consensus that quantum supremacy has been achieved.

1.3 Hilbert spaces

Every quantum mechanical system is associated with a Hilbert space \mathcal{V} , a complex inner product space that is a complete metric space with respect to the distance function induced by the inner product. We use Dirac's *bra-ket* notation: a vector is represented by $|\psi\rangle \in \mathcal{V}$, and its conjugate transpose is denoted $\langle\psi| \in \mathcal{V}^*$. If $\mathcal{V} = \mathbb{C}^n$, we write

$$|\psi\rangle = \begin{pmatrix} a_1 \\ \vdots \\ a_n \end{pmatrix}; \quad \langle\psi| = (a_1^* \quad \cdots \quad a_n^*)$$

The inner product of ψ and ϕ is written $\langle\psi|\phi\rangle$. Recall that an inner product satisfies

- $\langle\psi|\psi\rangle \geq 0$, and equal to zero if and only if $|\psi\rangle = 0$;
- linearity in the second argument, so $\langle\psi|a\phi_1 + b\phi_2\rangle = a\langle\psi|\phi_1\rangle + b\langle\psi|\phi_2\rangle$;
- antilinearity in the first argument, so $\langle a\psi_1 + b\psi_2|\phi\rangle = a^*\langle\psi_1|\phi\rangle + b^*\langle\psi_2|\phi\rangle$;
- skew-symmetry, so $\langle\psi|\phi\rangle^* = \langle\phi|\psi\rangle$;

and induces a norm $\|\psi\| = \|\psi\rangle\| = \sqrt{\langle\psi|\psi\rangle}$. In this course, we will often consider $\mathcal{V} = \mathbb{C}^2$ and define

$$|0\rangle = \begin{pmatrix} 1 \\ 0 \end{pmatrix}; \quad |1\rangle = \begin{pmatrix} 0 \\ 1 \end{pmatrix}$$

For an arbitrary $|\psi\rangle \in \mathbb{C}^2$, we can write $|\psi\rangle = a|0\rangle + b|1\rangle$, giving

$$|\psi\rangle = \begin{pmatrix} a \\ b \end{pmatrix}; \quad \langle\psi| = (a^* \quad b^*)$$

If $|\psi\rangle = c|0\rangle + d|1\rangle$, then $\langle\psi|\psi\rangle = a^*c + b^*d$.

We can also compute the *outer product* of two vectors, defined to be $|\psi\rangle\langle\phi|$. If $\mathcal{V} = \mathbb{C}^n$, the outer product is an $n \times n$ matrix. An orthonormal basis $(|i\rangle)_{i=1}^n$ for \mathcal{V} is called *complete* if $\sum_{i=1}^n |i\rangle\langle i|$ is the identity matrix.

If \mathcal{V} has a complete orthonormal basis, we can write $|\psi\rangle = \sum_{i=1}^n c_i |i\rangle$ for some c_i . If $\langle\psi|\psi\rangle = 1$, we say $|\psi\rangle$ is *normalised*. In this case, $\sum |c_i|^2 = 1$, and the $|c_i|^2$ form a discrete probability distribution. We call the c_i the *probability amplitudes*.

Let \mathcal{V}, \mathcal{W} be vector spaces, where $\dim \mathcal{V} = n, \dim \mathcal{W} = m$. Let $|\psi\rangle \in \mathcal{V}, |\phi\rangle \in \mathcal{W}$. Suppose $|\psi\rangle = (a_1 \quad \cdots \quad a_n)^T$, and $|\phi\rangle = (b_1 \quad \cdots \quad b_m)^T$. Then, $|\psi\rangle\langle\phi|$ is the *tensor product* of $|\psi\rangle$ and $|\phi\rangle$, defined

by

$$|v\rangle \otimes |w\rangle = \begin{pmatrix} a_1 b_1 \\ \vdots \\ a_1 b_m \\ a_2 b_1 \\ \vdots \\ a_n b_m \end{pmatrix} \in \mathcal{V} \otimes \mathcal{W}$$

If $(|e_i\rangle)_{i=1}^n$ is a complete orthonormal basis for \mathcal{V} and $(|f_j\rangle)_{j=1}^m$ is a complete orthonormal basis for \mathcal{W} , then $(|e_i\rangle \otimes |f_j\rangle)_{i,j=1}^{n,m}$ is a complete orthonormal basis for $\mathcal{V} \otimes \mathcal{W}$. We sometimes write $|v\rangle \otimes |w\rangle$ as $|v\rangle |w\rangle$ or $|vw\rangle$.

If $|\alpha\rangle \in \mathcal{V}$, we can write $|\alpha\rangle = \sum a_i |e_i\rangle$, and similarly if $|\beta\rangle \in \mathcal{W}$, we can write $|\beta\rangle = \sum b_j |f_j\rangle$. Then, $|\alpha\beta\rangle = \sum a_i b_j |e_i f_j\rangle$.

We say $|\Psi\rangle \in \mathcal{V} \otimes \mathcal{W}$ is a *product vector* if $|\Psi\rangle = |\psi\rangle \otimes |\phi\rangle$ for some ψ, ϕ . Vectors that are not product vectors are called *entangled vectors*.

Let $\mathcal{V} = \mathbb{C}^2 = \mathcal{W}$. Define $|\phi^+\rangle = \frac{1}{\sqrt{2}}(|00\rangle + |11\rangle)$. Suppose $|\phi^+\rangle = |\psi\rangle \otimes |\phi\rangle = (a|0\rangle + b|1\rangle) \otimes (c|0\rangle + d|1\rangle)$. Then, $|\phi^+\rangle = ac|00\rangle + ad|01\rangle + bc|10\rangle + bd|11\rangle$. So one of a and d , and one of b and c is equal to zero, contradicting the assumption, so $|\phi^+\rangle$ is entangled.

We define the inner product on the product space by defining

$$\langle \phi_1 | \psi_2 \rangle = (\langle \alpha_1 | \langle \beta_1 |) (\langle \beta_2 | | \alpha_2 \rangle) = \langle \alpha_1 | \alpha_2 \rangle \langle \beta_1 | \beta_2 \rangle$$

where $|\psi_i\rangle = |\alpha_i\rangle |\beta_i\rangle$. In the general case, $|A\rangle = \sum a_{ij} |e_i\rangle |f_j\rangle$, $|B\rangle = \sum b_{ij} |e_i\rangle |f_j\rangle$, and we define

$$\langle A | B \rangle = \left(\sum a_{ij}^* \langle e_i | \langle f_j | \right) \left(\sum b_{ij} |e_i\rangle |f_j\rangle \right) = \sum a_{ij}^* b_{ij} \delta_{ii'} \delta_{jj'} = \sum a_{ij}^* b_{ij}$$

where δ is the Kronecker δ symbol.

We define the k -fold *tensor power* of a vector space \mathcal{V} by

$$\mathcal{V}^{\otimes n} = \underbrace{\mathcal{V} \otimes \dots \otimes \mathcal{V}}_{n \text{ times}}$$

If $\mathcal{V} = \mathbb{C}^2$, this has dimension 2^k , and complete orthonormal basis $|i_1 \dots i_k\rangle$ for $i_j \in \{0, 1\}$. Note that $|v\rangle |w\rangle \neq |w\rangle |v\rangle$.

1.4 First postulate: quantum states

In this course, we will restrict our attention to finite-dimensional vector spaces, and finite time evolution. We describe the *postulates* for quantum mechanics that we will work under.

The first postulate is that, given an isolated quantum mechanical system S , we can associate a finite-dimensional vector space \mathcal{V} . The physical state of the system is given by a unit vector $|\psi\rangle$ in \mathcal{V} . More precisely, the state is given by a *ray*, an equivalence class of vectors $e^{i\theta} |\psi\rangle$ for $\theta \in \mathbb{R}$. No measurements can distinguish states in a given equivalence class. Note that states $a|\psi_1\rangle + b|\psi_2\rangle$ and $a|\psi_1\rangle + be^{i\theta} |\psi_2\rangle$ can be distinguished by measurement, since the phase difference is relative, not global.

Example. Let $\mathcal{V} = \mathbb{C}^2$ with (complete orthonormal) basis $|0\rangle, |1\rangle$. The elementary unit of quantum information is known as the *qubit*, which is any quantum system with $\mathcal{V} = \mathbb{C}^2$. The spin of an electron, which is some superposition of spin-up and spin-down, can be modelled by \mathbb{C}^2 . A property of the polarisation of a photon, such as vertical or horizontal, or right-circular or left-circular, can also be modelled in this way.

Define $|+\rangle = \frac{1}{\sqrt{2}}(|0\rangle + |1\rangle)$ and $|-\rangle = \frac{1}{\sqrt{2}}(|0\rangle - |1\rangle)$. This is another complete orthonormal basis for \mathcal{V} , sometimes called the *conjugate basis*.

1.5 Second postulate: composite systems

The second postulate of quantum mechanics is that two quantum systems S_1, S_2 with associated vector spaces $\mathcal{V}_1, \mathcal{V}_2$ can be composed into the *composite system* with vector space $\mathcal{V}_1 \otimes \mathcal{V}_2$.

Example. Consider $\mathcal{V}^{\otimes n}$, the space of n qubits. An orthonormal basis is $|i_1 \dots i_n\rangle$ where $i_j \in \{0, 1\}$. A vector in $\mathcal{V}^{\otimes n}$ can be written $\sum a_{i_1 \dots i_n} |i_1 \dots i_n\rangle$. There are 2^n different amplitudes $a_{i_1 \dots i_n}$, providing exponential growth in information. However, in a product state, we obtain only linear growth in information.

1.6 Observables

An *observable* is a property of a physical system which can, in theory, be measured. Mathematically, these are modelled by linear self-adjoint (or Hermitian) operators.

The action of a linear operator A on a state space \mathcal{V} is written $A|\psi\rangle$. By linearity, we have $A(a|\psi\rangle + b|\phi\rangle) = aA|\psi\rangle + bA|\phi\rangle$ for $a, b \in \mathbb{C}$. For any operator A acting on \mathcal{V} , there is a unique linear operator A^\dagger such that $\langle v|Aw\rangle = \langle A^\dagger v|w\rangle$, called the *adjoint* of A ; operators equal to their adjoints are called *self-adjoint*.

We can easily show that $(AB)^\dagger = B^\dagger A^\dagger$. By convention, we define $|\psi\rangle^\dagger = \langle\psi|$, so for a self-adjoint operator A , we have $(A|\psi\rangle)^\dagger = \langle\psi|A$. There are four important operators which act on the single-qubit space \mathbb{C}^2 .

$$\sigma_0 = \begin{pmatrix} 1 & 0 \\ 0 & 1 \end{pmatrix}; \quad \sigma_x = \begin{pmatrix} 0 & 1 \\ 1 & 0 \end{pmatrix}; \quad \sigma_y = \begin{pmatrix} 0 & -i \\ i & 0 \end{pmatrix}; \quad \sigma_z = \begin{pmatrix} 1 & 0 \\ 0 & -1 \end{pmatrix}$$

σ_0 is the identity matrix, and $\sigma_x, \sigma_y, \sigma_z$ are called the *Pauli matrices*. The actions of these matrices on the basis vectors $|0\rangle$ and $|1\rangle$ are

$$\begin{aligned} \sigma_0|0\rangle &= |0\rangle; & \sigma_0|1\rangle &= |1\rangle; & \sigma_x|0\rangle &= |1\rangle; & \sigma_x|1\rangle &= |0\rangle; \\ \sigma_y|0\rangle &= i|1\rangle; & \sigma_y|1\rangle &= -i|0\rangle; & \sigma_z|0\rangle &= |0\rangle; & \sigma_z|1\rangle &= -|1\rangle \end{aligned}$$

Note that

$$\sigma_x\sigma_y = i\sigma_z; \quad \sigma_y\sigma_z = i\sigma_x; \quad \sigma_z\sigma_x = i\sigma_y$$

Intuitively, σ_x is a bit flip, σ_y is a phase flip, and σ_z is a combined bit and phase flip.

1.7 Dirac notation for linear operators

Let $|v\rangle = a|0\rangle + b|1\rangle$, and $|w\rangle = c|0\rangle + d|1\rangle$. The outer product is

$$M = |v\rangle\langle w| = \begin{pmatrix} a \\ b \end{pmatrix} (c^* \quad d^*) = \begin{pmatrix} ac^* & ad^* \\ bc^* & bd^* \end{pmatrix}$$

which is a linear map on $\mathcal{V} = \mathbb{C}^2$. One can show that $M|x\rangle = (|v\rangle\langle w|)|x\rangle = |v\rangle\langle w|x\rangle$, which is the scalar product of the vector $|v\rangle$ with the inner product $\langle w|x\rangle$. Such outer products yield the linear maps from \mathbb{C}^2 to \mathbb{C}^2 that have rank 1, and the kernel of M is the subspace of vectors orthogonal to $|w\rangle$. Note that

$$|0\rangle\langle 0| = \begin{pmatrix} 1 & 0 \\ 0 & 0 \end{pmatrix}; \quad |0\rangle\langle 1| = \begin{pmatrix} 0 & 1 \\ 0 & 0 \end{pmatrix}; \quad |1\rangle\langle 0| = \begin{pmatrix} 0 & 0 \\ 1 & 0 \end{pmatrix}; \quad |1\rangle\langle 1| = \begin{pmatrix} 0 & 0 \\ 0 & 1 \end{pmatrix}$$

Hence, we can write

$$A = \begin{pmatrix} a & b \\ c & d \end{pmatrix} \implies A = a|0\rangle\langle 0| + b|0\rangle\langle 1| + c|1\rangle\langle 0| + d|1\rangle\langle 1|$$

In particular, $|0\rangle\langle 0|, |0\rangle\langle 1|, |1\rangle\langle 0|, |1\rangle\langle 1|$ forms a basis for the vector space $\mathcal{V} \otimes \mathcal{V}^*$ of linear maps on \mathcal{V} . Note also that $\langle w|v\rangle = \text{Tr}|v\rangle\langle w|$.

1.8 Projection operators

Suppose that $|v\rangle$ is a normalised vector, so $\langle v|v\rangle = 1$. Then, $\Pi_v = |v\rangle\langle v|$ is the *projection operator* onto v , satisfying $\Pi_v\Pi_v = \Pi_v$ and $\Pi_v^\dagger = \Pi_v$. In Dirac notation, one can see that

$$\Pi_v\Pi_v = |v\rangle\langle v||v\rangle\langle v| = |v\rangle\langle v|v\rangle\langle v| = |v\rangle\langle v| = \Pi_v$$

If $|a\rangle$ is orthogonal to $|v\rangle$, then $\Pi_v|a\rangle = |v\rangle\langle v|a\rangle = 0$. Therefore, $\Pi_v|x\rangle$ is the vector obtained by projection of $|x\rangle$ onto the one-dimensional subspace of \mathcal{V} spanned by $|v\rangle$.

Now suppose \mathcal{E} is any linear subspace of some vector space \mathcal{V} , and $|e_1\rangle, \dots, |e_d\rangle$ is any orthonormal basis of \mathcal{E} . Then,

$$\Pi_{\mathcal{E}} = |e_1\rangle\langle e_1| + \dots + |e_d\rangle\langle e_d|$$

is the projection operator into \mathcal{E} . This property can be checked by extending $|e_1\rangle, \dots, |e_d\rangle$ into an orthonormal basis of \mathcal{V} .

Note that if $|x\rangle = A|v\rangle$, then $\langle x| = (A|v\rangle)^\dagger = |v\rangle^\dagger A^\dagger = \langle v|A^\dagger$. Therefore, when constructing inner products, we can write $\langle a|M|b\rangle$ as $\langle a|x\rangle$ or $\langle y|b\rangle$ where $|x\rangle = M|b\rangle$ or $|y\rangle = M^\dagger|a\rangle$ (so that we have $\langle y| = \langle a|M$).

1.9 Tensor products of linear maps

Suppose A, B are linear maps $\mathbb{C}^2 \rightarrow \mathbb{C}^2$. Then, we define $A \otimes B : \mathbb{C}^2 \otimes \mathbb{C}^2 \rightarrow \mathbb{C}^2 \otimes \mathbb{C}^2$ by its action on the basis $(A \otimes B)|i\rangle|j\rangle = A|i\rangle B|j\rangle$. In particular, for product vectors we obtain $(A \otimes B)(|v\rangle|w\rangle) = A|v\rangle \otimes B|w\rangle$.

The 4×4 matrix of components of $A \otimes B$ has a simple block form, which can be seen by writing down its action on basis states.

$$A = \begin{pmatrix} a & b \\ c & d \end{pmatrix}; \quad B = \begin{pmatrix} p & q \\ r & s \end{pmatrix} \implies A \otimes B = \begin{pmatrix} aB & bB \\ cB & dB \end{pmatrix} = \begin{pmatrix} ap & aq & bp & bq \\ ar & as & br & bs \\ cp & cq & dp & dq \\ cr & cs & dr & ds \end{pmatrix}$$

Note that $A \otimes I$ and $I \otimes A$ can be thought of as acting only on one of the subspaces. Consider $|\Phi\rangle = \frac{1}{\sqrt{2}}(|00\rangle + |11\rangle)$, and define A as above. Then,

$$\begin{aligned}
(A \otimes I) |\Phi\rangle &= \frac{1}{\sqrt{2}}[(A|0\rangle)|0\rangle + (A|1\rangle)|1\rangle] \\
&= \frac{1}{\sqrt{2}}[(a|0\rangle + c|1\rangle)|0\rangle + (b|0\rangle + d|1\rangle)|1\rangle] \\
&= \frac{1}{\sqrt{2}}[a|00\rangle + b|01\rangle + c|10\rangle + d|11\rangle] \\
(I \otimes A) |\Phi\rangle &= \frac{1}{\sqrt{2}}[|0\rangle(A|0\rangle) + |1\rangle(A|1\rangle)] \\
&= \frac{1}{\sqrt{2}}[|0\rangle(a|0\rangle + c|1\rangle) + |1\rangle(b|0\rangle + d|1\rangle)] \\
&= \frac{1}{\sqrt{2}}[a|00\rangle + c|01\rangle + b|10\rangle + d|11\rangle]
\end{aligned}$$

1.10 Third postulate: physical evolution of quantum systems

The third postulate of quantum mechanics is that any physical finite-time evolution of a closed quantum system is represented by a unitary operation on the corresponding vector space of states. Recall that the following are equivalent for a linear operator U :

- U is unitary, so $U^{-1} = U^\dagger$;
- U maps an orthonormal basis to an orthonormal set of vectors;
- the columns (or rows) of U form an orthonormal set of vectors.

If a system is in a state $|\psi(t_1)\rangle$ at a time t_1 and later in a state $|\psi(t_2)\rangle$ at a time t_2 , then $|\psi(t_2)\rangle = U(t_1, t_2)|\psi(t_1)\rangle$ for some unitary map $U(t_1, t_2)$ which depends only on t_1, t_2 . This operator is derived from the *Schrödinger equation*, which is

$$i\hbar \frac{\partial}{\partial t} |\psi(t)\rangle = H |\psi(t)\rangle$$

where H is a self-adjoint operator known as the *Hamiltonian*. In particular, if H is time-independent, we have

$$U(t_1, t_2) = e^{-\frac{i}{\hbar} H(t_2 - t_1)}$$

In the more general case,

$$U(t_1, t_2) = e^{-\frac{i}{\hbar} \int_{t_1}^{t_2} H(t) dt}$$

The unitary evolution of a closed system is deterministic.

1.11 Partial inner products

A vector $|v\rangle \in \mathcal{V}$ defines a linear map $\mathcal{V} \otimes \mathcal{W} \rightarrow \mathcal{W}$ called the *partial inner product* with $|v\rangle$, defined on the basis $|e_i\rangle|f_j\rangle$ of $\mathcal{V} \otimes \mathcal{W}$ by $|e_i\rangle|f_j\rangle \mapsto \langle v|e_i\rangle|f_j\rangle$. Similarly, for any $|w\rangle \in \mathcal{W}$, we obtain a partial inner product $\mathcal{V} \otimes \mathcal{W} \rightarrow \mathcal{V}$. If \mathcal{V}, \mathcal{W} are isomorphic, we must specify which partial inner product is intended.

1.12 Fourth postulate: quantum measurement

Consider a system S with state space \mathcal{V} , and let A be an observable. A can be written as its *spectral projection* $A = \sum_k a_k P_k$ where $A|\varphi_k\rangle = a_k|\varphi_k\rangle$. If a_k is nondegenerate, $P_k = |\varphi_k\rangle\langle\varphi_k|$. If a_k is degenerate of multiplicity m , then $P_k = \sum_{i=1}^m |\varphi_k^i\rangle\langle\varphi_k^i|$.

The fourth postulate is that when an observable is measured, the resulting measurement will be an eigenvalue a_j , with probability $p(a_j) = \langle\psi|P_j|\psi\rangle$. Then, $|\psi\rangle$ is replaced with the post-measurement state

$$\frac{P_j|\psi\rangle}{\sqrt{p(a_j)}}$$

This is known as *Born's rule*. Such a measurement is called a *projective measurement* (or sometimes a *von Neumann measurement*), since the post-measurement state is given by a projection operator.

Suppose A, B are operators that do not commute, so $[A, B] = AB - BA \neq 0$. Then, the measurement of A will influence the outcome probabilities of a subsequent measurement of B . For instance, suppose $|\psi\rangle = |+\rangle, A = \sigma_z, B = \sigma_x$.

1.13 Complete and incomplete projective measurements

Let $|\psi\rangle \in \mathcal{V}$ be a state in a state space of dimension n . Let $\mathcal{B} = \{|e_i\rangle\}$ be a set of n orthogonal basis vectors for \mathcal{V} . Then $|\psi\rangle = \sum a_j |e_j\rangle$ where $a_k = \langle e_k|\psi\rangle$. If the outcomes of a measurement are the indices of the basis vectors $j = 1, \dots, n$, we have $p(j) = \langle\psi|P_j|\psi\rangle$ where $P_j = |e_j\rangle\langle e_j|$. Therefore, $p(j) = |\langle\psi|e_j\rangle|^2 = |a_j|^2$. If the outcome is j , the post-measurement state is

$$\frac{P_j|\psi\rangle}{\sqrt{p(j)}} = \frac{|e_j\rangle\langle e_j|\psi\rangle}{\sqrt{p(j)}} = |e_j\rangle$$

Hence the state collapses to a basis vector. Taking another measurement immediately in the same basis, we obtain the result j with probability 1. Such a measurement is called a *complete* projective measurement; it is called complete as all P_j are of rank 1. When we measure a state $|\psi\rangle$ in a basis, it is often helpful to consider an orthogonal decomposition of \mathcal{V} using the basis vectors.

Conversely, an *incomplete* projective measurement corresponds to an arbitrary orthogonal decomposition of \mathcal{V} . Consider a decomposition of \mathcal{V} into d mutually orthogonal subspaces $\mathcal{E}_1, \dots, \mathcal{E}_d$, so $\mathcal{V} = \mathcal{E}_1 \oplus \dots \oplus \mathcal{E}_d$, and $\dim \mathcal{V} = \sum \dim \mathcal{E}_j$. Let Π_i be a projection operator onto \mathcal{E}_i . Since the spaces are mutually orthogonal, $\Pi_i\Pi_j = \delta_{ij}\Pi_i$. Consider a measurement with outcomes $1, \dots, d$ representing a particular subspace. The probability of observing outcome i is $\langle\psi|\Pi_i|\psi\rangle$. If the outcome is i , $|\psi\rangle$ is replaced with $\frac{\Pi_i|\psi\rangle}{\sqrt{p(i)}}$. In this case, the Π_i are no longer rank 1 projection operators. If \mathcal{E}_i has basis $\{|f_j\rangle\}$, we can write $\Pi_i = \sum |f_j\rangle\langle f_j|$.

Incomplete projective measurement is a generalisation of complete projective measurement. One can refine an incomplete measurement into a complete measurement by first considering a complete measurement, and then summing the relevant outcome probabilities to obtain a description of the incomplete measurement probabilities. Let $\{|e_k^{(j)}\rangle\}_{k=1}^{d_j}$ be a basis for \mathcal{E}_j for each j . Then $\mathcal{V} = \bigoplus_{j=1}^d \mathcal{E}_j$ has orthonormal basis $\{|e_k^{(j)}\rangle\}_{j,k}$. Then, $\langle e_i^{(k_1)}|e_j^{(k_2)}\rangle = \delta_{ij}\delta_{k_1k_2}$.

Consider a two-bit string $b_1 b_2$. The *parity* of this string is $b_1 \oplus b_2$, where \oplus represents addition modulo 2. Consider the orthogonal decomposition of \mathcal{V} into $\mathcal{E}_0 \oplus \mathcal{E}_1$, where $\mathcal{E}_0 = \text{span}\{|00\rangle, |11\rangle\}$ is the even parity subspace, and $\mathcal{E}_1 = \text{span}\{|01\rangle, |10\rangle\}$ is the odd parity subspace. The outcomes of an incomplete measurement are then the labels 0 and 1 of the subspaces \mathcal{E}_0 and \mathcal{E}_1 . Note that $\{|00\rangle, |01\rangle, |10\rangle, |11\rangle\}$ is a complete orthonormal basis for \mathcal{V} , so we can consider the complete projective measurement. $\langle \psi | P_{00} | \psi \rangle$ is the probability of outcome 00 for the complete measurement, where $P_{00} = |00\rangle\langle 00|$. For the incomplete measurement, $p(0) = \langle \psi | \Pi_0 | \psi \rangle$ is the probability of outcome 0, where $\Pi_0 = P_{00} + P_{11}$. So $p(0) = \langle \psi | P_{00} | \psi \rangle + \langle \psi | P_{11} | \psi \rangle$.

1.14 Extended Born rule

Let S_1, S_2 be quantum systems with state spaces \mathcal{V}, \mathcal{W} with dimensions m, n , and we consider the composite system $S_1 S_2$. Let $\{|e_i\rangle\}$ be a complete orthonormal basis of \mathcal{V} , and let $\{|f_j\rangle\}$ be a complete orthonormal basis of \mathcal{W} . Suppose the composite system is in an initial state $|\psi\rangle = \sum a_{ij} |e_i\rangle |f_j\rangle$. Suppose now that we want to measure $|\psi\rangle$ in the basis $\{|e_i\rangle\}$; this amounts to an incomplete measurement with subspaces $\mathcal{E}_i = \text{span}\{|e_i\rangle \otimes |\varphi\rangle \mid |\varphi\rangle \in \mathcal{W}\}$ for $1 \leq i \leq m$. The outcomes of such a measurement are $\{1, \dots, m\}$, and the \mathcal{E}_i are mutually orthogonal. The probability of a given outcome is $p(k) = \langle \psi | P_k \otimes I | \psi \rangle$, where $P_k = |e_k\rangle\langle e_k|$. Hence,

$$p(k) = \left(\sum a_{i'j'}^* \langle e_{i'} | \langle f_{j'} | \right) (|e_k\rangle\langle e_k| \otimes I) \left(\sum a_{ij} |e_i\rangle |f_j\rangle \right) = \sum_{j=1}^n a_{kj}^* a_{kj}$$

If the outcome is k , then the post-measurement state is given by

$$|\psi_{\text{after}}\rangle = \frac{(P_k \otimes I) |\psi\rangle}{p(k)} = \frac{\sum_j a_{kj} |e_k\rangle |f_j\rangle}{\sqrt{\sum_j |a_{kj}|^2}}$$

Using partial inner products, one can show that $|\psi_{\text{after}}\rangle$ is normalised. These rules are referred to as the *extended Born rule*.

Consider a quantum system S with state space \mathcal{V} . A measurement relative to any basis \mathcal{C} can be performed by first performing a unitary operator, then performing a measurement in a fixed basis \mathcal{B} . Let $\mathcal{B} = \{|e_i\rangle\}$, and $\mathcal{C} = \{|e'_i\rangle\}$. Let U be a unitary operator such that $|e'_i\rangle = U |e_i\rangle$. Then, $U^\dagger = U^{-1}$ has the property that $U^{-1} |e'_i\rangle = |e_i\rangle$. Suppose we have a state $|\psi\rangle \in \mathcal{V}$. Let $|\psi\rangle = \sum c_i |e'_i\rangle$. Applying U^{-1} to $|\psi\rangle$, we obtain $U^{-1} |\psi\rangle = \sum c_i |e_i\rangle$ by linearity. We can then measure $|\psi'\rangle = U^{-1} |\psi\rangle$ in the basis \mathcal{B} . By the Born rule, $p(i) = \langle \psi' | P_i | \psi' \rangle = \langle \psi | U P_i U^\dagger | \psi \rangle$ where $P_i = |e_i\rangle\langle e_i|$, as we are performing a complete projective measurement. If the outcome is i , then the post-measurement state is $|\psi'_{\text{after}}\rangle = \frac{P_i |\psi'\rangle}{p(i)}$.

1.15 Standard measurement on multi-qubit systems

Consider a system of n qubits. The state space is $(\mathbb{C}^2)^{\otimes n}$. The *computational basis* or *standard basis* is $\mathcal{B} = \{|i_1 \dots i_n\rangle \mid i_j \in \{0, 1\}\}$. The labels of the elements of the standard basis are labelled by bit strings of length n .

Suppose we are measuring a subset of k qubits of the n -qubit system. Let $n = 3$, and let

$$|\psi\rangle = \frac{i}{2} |000\rangle + \frac{1+i}{2\sqrt{2}} |001\rangle - \frac{1}{2} |101\rangle + \frac{3}{10} |110\rangle - \frac{2i}{5} |111\rangle$$

The standard measurement of any of the three qubits will always have the outcome zero or one. Suppose we perform a standard measurement on the first qubit. By the extended Born rule, we obtain

$$p^{(1)}(1) = \langle \psi | P_1 \otimes I \otimes I | \psi \rangle = \langle \psi | (|1\rangle\langle 1| \otimes I \otimes I) | \psi \rangle = \frac{1}{4} + \frac{9}{100} + \frac{4}{25} = \frac{1}{2}$$

If we measure the outcome 1, the post-measurement state is $|\psi_{\text{after}}\rangle = \frac{(P_1 \otimes I \otimes I) |\psi\rangle}{\sqrt{p^{(1)}(1)}}$.

1.16 Reliably distinguishing states

Note that the measurement postulate implies that states with guaranteed (with probability 1) different measurement outcomes always lie in mutually orthogonal subspaces. We say that two states are *reliably distinguishable* if there exists a measurement which outputs two distinct outcomes with probability 1 when applied to the two states. Therefore, two states $|\psi\rangle, |\varphi\rangle$ are reliably distinguishable if and only if they are orthogonal, so $\langle \psi | \varphi \rangle = 0$.

Let $|\psi\rangle$ and $|\varphi\rangle$ be orthogonal. Let $\mathcal{B} = \{|\psi\rangle, |f_1\rangle, \dots, |f_{m-1}\rangle\}$ be a complete orthonormal basis for \mathcal{V} . Then $\langle \psi | f_j \rangle = 0$ and $\langle f_j | f_k \rangle = \delta_{jk}$. Measuring $|\psi\rangle$ in this basis, $p(1) = \langle \psi | P_1 | \psi \rangle$ where $P_1 = |\psi\rangle\langle \psi|$, so the probability is 1. Measuring $|\varphi\rangle$ in this basis, $p(1) = \langle \psi | \varphi \rangle \langle \varphi | \psi \rangle = 0$. This is an example of a measurement which can reliably distinguish $|\psi\rangle$ and $|\varphi\rangle$.

Vectors $|v\rangle = |\psi\rangle$ and $|v'\rangle = e^{i\theta} |\psi\rangle$ are not distinguishable. For any measurement, the probability of obtaining a particular outcome when measuring $|v\rangle$ is always the same as the probability when measuring $|v'\rangle$.

2 Quantum states as information carriers

2.1 Using higher Hilbert spaces

Quantum information is encoded in the states of a quantum system. Classical information is encoded in states chosen from an orthonormal set, since all distinct classical messages can be distinguished. Given a quantum system S and a quantum state $|\psi\rangle$, we can perform this sequence of operations.

- (ancilla) Consider an auxiliary system A in a fixed state $|A\rangle \in \mathcal{V}_A$. The composite system SA has vector space $\mathcal{V}_S \otimes \mathcal{V}_A$. The initial joint state is $|\psi\rangle |A\rangle$. This results in an embedding of quantum information in a higher dimensional space.
- (unitary) Consider the action of a unitary operator U on SA (or on S), modelling the time evolution of the quantum system.
- (measure) We can perform measurements on SA (or on S). The post-measurement state of S is retained, and the auxiliary system A is discarded.

This process is sometimes known as ‘going to the church of the higher Hilbert space’. The presence of the ancilla allows for entanglement with other quantum systems.

2.2 No-cloning theorem

Classically, information can be easily copied by measuring all relevant information and reproducing it. Quantum copying involves three systems:

- a system A containing some quantum information to be copied;
- a system B with $\mathcal{V}_B \simeq \mathcal{V}_A$ initially in some fixed state $|0\rangle$ where the information is to be copied;
- a system M which represents any physical machinery in some ‘ready’ state $|M_0\rangle$ required for performing the copy.

The initial state of this composite system ABM is $|\psi\rangle|0\rangle|M_0\rangle$. Note that the $|\psi\rangle$ and $|0\rangle|M_0\rangle$ are *uncorrelated* in this state, as we are using the tensor product to combine them. Suppose that the cloning process is performed using some unitary operator U , so $U|\psi_A\rangle|0\rangle|M_0\rangle = |\psi_A\rangle|\psi_B\rangle|M_\psi\rangle$. This cloning process may be required to work either for all states of A , or for some subset of A .

Theorem. Let \mathcal{S} be any set of states of the system A that contains at least one pair of distinct non-orthogonal states. Then there does not exist any unitary operator U that clones all states in \mathcal{S} .

Proof. Let $|\xi\rangle, |\eta\rangle$ be distinct non-orthogonal states in \mathcal{S} , so $\langle\xi|\eta\rangle \neq 0$. Suppose such a unitary operator U exists. Then, we must have

$$U|\xi_A\rangle|0_B\rangle|M_0\rangle = |\xi_A\rangle|\xi_B\rangle|M_\xi\rangle; \quad U|\eta_A\rangle|0_B\rangle|M_0\rangle = |\eta_A\rangle|\eta_B\rangle|M_\eta\rangle$$

Unitary operators preserve inner products. Hence,

$$\langle\xi_A|\eta_A\rangle\langle 0_B|0_B\rangle\langle M_0|M_0\rangle = \langle\xi_A|\eta_A\rangle\langle\xi_B|\eta_B\rangle\langle M_\xi|M_\eta\rangle$$

Hence, $\langle\xi|\eta\rangle = (\langle\xi|\eta\rangle)^2 \langle M_\xi|M_\eta\rangle$. By taking the absolute value, $|\langle\xi|\eta\rangle| = |\langle\xi|\eta\rangle|^2 |\langle M_\xi|M_\eta\rangle|$. Since $\xi \neq \eta$, we must have $0 < |\langle\xi|\eta\rangle| < 1$, and $0 \leq |\langle M_\xi|M_\eta\rangle| \leq 1$. Therefore, $1 = |\langle\xi|\eta\rangle| |\langle M_\xi|M_\eta\rangle| < 1$, which is a contradiction. \square

If quantum cloning were possible, superluminal (indeed, instantaneous) communication would also be possible. Suppose we have a state $|\psi_{AB}^+\rangle = \frac{1}{\sqrt{2}}(|00\rangle + |11\rangle) \in \mathbb{C}^2 \otimes \mathbb{C}^2$. Let A, B be the entangled parts of this quantum state, and suppose that we send qubit A to Alice and B to Bob, far apart from each other.

If we want to send the bit ‘yes’ from Alice to Bob, we measure the qubit A in the basis $\{|0\rangle, |1\rangle\}$, which gives outcomes 0, 1 with probability $\frac{1}{2}$. If the outcome is 0, the final state of B is $|0\rangle$, and if the outcome is 1, the final state of B is $|1\rangle$. If we want to send ‘no’, we instead measure A in the basis $\{|+\rangle, |-\rangle\}$, which gives the outcomes $+, -$ with probability $\frac{1}{2}$. Similarly, the final state of B is $|+\rangle$ or $|-\rangle$.

We claim that these ‘yes’ ($|0\rangle, |1\rangle$) and ‘no’ ($|+\rangle, |-\rangle$) *preparations* of qubit B are indistinguishable by Bob with any local action on the qubit. That is, they each give exactly the same probability distribution of outcomes of any measurement. In fact, the distribution matches the prior distribution before qubit A was measured.

Let Π_i be the projection operator for outcome i on qubit B . Suppose that ‘yes’ was sent. Then,

$$p_{\text{yes}}(i) = \frac{1}{2} \langle 0|\Pi_i|0\rangle + \frac{1}{2} \langle 1|\Pi_i|1\rangle = \frac{1}{2} \text{Tr} [\Pi_i(|0\rangle\langle 0| + |1\rangle\langle 1|)] = \frac{1}{2} \text{Tr} \Pi_i$$

In the ‘no’ case,

$$p_{\text{no}}(i) = \frac{1}{2} \langle +|\Pi_i|+\rangle + \frac{1}{2} \langle -|\Pi_i|-\rangle = \frac{1}{2} \text{Tr} [\Pi_i(|+\rangle\langle +| + |-\rangle\langle -|)] = \frac{1}{2} \text{Tr} \Pi_i$$

These probability distributions match.

Suppose that cloning were possible. We clone the qubit B multiple times after the message was sent, to produce one of the states $|0\rangle \dots |0\rangle, |1\rangle \dots |1\rangle, |+\rangle \dots |+\rangle, |-\rangle \dots |-\rangle$. We now measure each qubit in the basis $|0\rangle, |1\rangle$ separately. If the ‘yes’ message was sent, all measurements will result in 0 or 1. If ‘no’ was sent, it is possible that two measurements would differ. In expectation, half of the measurements would result in the outcome 0 and half would result in the outcome 1. Therefore, the ‘yes’ and ‘no’ errors can be distinguished with probability of error 2^{-N+1} if we make N copies of B .

2.3 Distinguishing non-orthogonal states

Suppose you know a state $|\psi\rangle$ has state $|\alpha_0\rangle$ or $|\alpha_1\rangle$ with probability $\frac{1}{2}$, where $\langle\alpha_0|\alpha_1\rangle \neq 0$. Since the states are non-orthogonal, we cannot perfectly distinguish the states, but must allow some error rate. The simplest possibility is to not make a measurement and guess randomly; in which case, the guess is correct with probability $\frac{1}{2}$.

Suppose we append an auxiliary system $|A\rangle$ to $|\alpha_i\rangle$. Note that $\langle A|\langle\alpha_i|\alpha_i\rangle|A\rangle = \langle\alpha_i|\alpha_i\rangle$ as $|A\rangle$ is normalised. If we apply a unitary operator U to $|\alpha_i\rangle$ then perform a projective measurement in the basis $\{\Pi_0, \Pi_1\}$, our action corresponds to simply performing a measurement $\Pi'_0 = U^\dagger \Pi_0 U$ or $\Pi'_1 = U^\dagger \Pi_1 U$, which leads to the same probabilities of outcomes. Indeed,

$$p(i) = \langle U\xi|\Pi_i|U\xi\rangle = \langle \xi|U^\dagger \Pi_i U|\xi\rangle = \langle \xi|\Pi'_i|\xi\rangle$$

Therefore, in this particular problem, we gain no benefit from moving to a larger Hilbert space or applying unitary operators.

We now describe the *state estimation* or *state discrimination* process. We will consider a two-outcome measurement $\{\Pi_0, \Pi_1\}$, where $\Pi_0 + \Pi_1 = I$. The average success probability is

$$\begin{aligned} p_S(\Pi_0, \Pi_1) &= \frac{1}{2} \mathbb{P}(0 | |\psi\rangle = |\alpha_0\rangle) + \frac{1}{2} \mathbb{P}(1 | |\psi\rangle = |\alpha_1\rangle) \\ &= \frac{1}{2} \langle\alpha_0|\Pi_0|\alpha_0\rangle + \frac{1}{2} \langle\alpha_1|\Pi_1|\alpha_1\rangle \\ &= \frac{1}{2} + \frac{1}{2} \text{Tr}[\Pi_0(|\alpha_0\rangle\langle\alpha_0| - |\alpha_1\rangle\langle\alpha_1|)] \end{aligned}$$

as $\text{Tr}(A|\psi\rangle\langle\psi|) = \langle\alpha|\alpha\rangle$. The optimal choice of measurement maximises the average success probability p_S . Note that $\Delta = |\alpha_0\rangle\langle\alpha_0| - |\alpha_1\rangle\langle\alpha_1|$ is self-adjoint, and we can write $p_S = \frac{1}{2} + \frac{1}{2} \text{Tr}(\Pi_0 \Delta)$. Therefore, the eigenvalues of Δ are real, and the eigenvectors form an orthonormal basis. For a state $|\beta\rangle$ orthogonal to both $|\alpha_0\rangle$ and $|\alpha_1\rangle$, we have $\Delta|\beta\rangle = 0$. Therefore, Δ acts nontrivially only in the vector space spanned by $|\alpha_0\rangle$ and $|\alpha_1\rangle$, and hence has at most two nonzero eigenvalues, and its eigenvectors lie in $\text{span}\{|\alpha_0\rangle, |\alpha_1\rangle\}$.

Now, $\text{Tr} \Delta = 0$ so the eigenvalues are δ and $-\delta$ for some $\delta \in \mathbb{R}$. Let $|p\rangle$ be the eigenvector for δ , and $|m\rangle$ be the eigenvector for $-\delta$, so $\langle p|m\rangle = 0$. We can write Δ in its spectral decomposition, giving $\Delta = \delta |p\rangle\langle p| - \delta |m\rangle\langle m|$.

Let $|\alpha_0^\perp\rangle \in \text{span}\{|\alpha_0\rangle, |\alpha_1\rangle\}$ be a normalised vector such that $\langle\alpha_0^\perp|\alpha_0\rangle = 0$. Then, $\{|\alpha_0\rangle, |\alpha_0^\perp\rangle\}$ is an orthonormal basis. Hence, we can write $|\alpha_1\rangle = c_0 |\alpha_0\rangle + c_1 |\alpha_0^\perp\rangle$. In this basis,

$$\Delta = \begin{pmatrix} 1 & 0 \\ 0 & 0 \end{pmatrix} + \begin{pmatrix} -|c_0|^2 & -c_0 c_1^* \\ -c_0^* c_1 & -|c_1|^2 \end{pmatrix} = \begin{pmatrix} 1 - |c_0|^2 & -c_0 c_1^* \\ -c_0^* c_1 & -|c_1|^2 \end{pmatrix} = \begin{pmatrix} |c_1|^2 & -c_0 c_1^* \\ -c_0^* c_1 & -|c_1|^2 \end{pmatrix}$$

which has eigenvalues $\delta = |c_1|, -\delta = -|c_1|$. Since $|c_0| = |\langle \alpha_0 | \alpha_1 \rangle| = \cos \theta$ where $\theta \geq 0$, we have $\delta = \sin \theta$. Then,

$$\begin{aligned} p_S(\Pi_0, \Pi_1) &= \frac{1}{2} + \frac{1}{2} \text{Tr}(\Pi_0 \Delta) \\ &= \frac{1}{2} + \frac{1}{2} \text{Tr}(\Pi_0 [\sin \theta |p\rangle\langle p| - \sin \theta |m\rangle\langle m|]) \\ &= \frac{1}{2} + \frac{\sin \theta}{2} [\langle p | \Pi_0 | p \rangle - \langle m | \Pi_0 | m \rangle] \end{aligned}$$

Note that for any $|\varphi\rangle$, we have $0 \leq \langle \varphi | \Pi | \varphi \rangle \leq 1$, so the measurement is maximised when $\langle p | \Pi_0 | p \rangle = 1$ and $\langle m | \Pi_0 | m \rangle = 0$. We therefore define $\Pi_0 = |p\rangle\langle p|$. Then, the optimal average success probability is

$$p_S^* = \frac{1}{2} + \frac{\sin \theta}{2}$$

Theorem (Holevo–Helstrom theorem for pure states). Let $|\alpha_0\rangle, |\alpha_1\rangle$ be equally likely states, with $|\langle \alpha_0 | \alpha_1 \rangle| = \cos \theta, \theta \geq 0$. Then, the probability p_S of correctly identifying the state by any quantum measurement satisfies

$$p_S \leq \frac{1}{2} + \frac{\sin \theta}{2}$$

and this bound can be attained.

In the case of orthogonal states, the theorem implies that $p_S \leq 1$ and the bound can be attained, which was shown before.

2.4 No-signalling principle

Suppose we have a possibly entangled state $|\phi_{AB}\rangle \in \mathcal{V}_A \otimes \mathcal{V}_B$ shared between two agents Alice (A) and Bob (B). Suppose we perform a complete projective measurement on $|\phi_A\rangle$. By the extended Born rule, each measurement outcome will lead to an instantaneous change of $|\phi_B\rangle$. If this change in state could be detected by measuring $|\phi_B\rangle$, instantaneous communication between A and B would be possible.

Consider $|\phi_{AB}^+\rangle = \frac{1}{\sqrt{2}}(|00\rangle + |11\rangle)$. Suppose qubit A is measured in the standard basis $\{|0\rangle, |1\rangle\}$.

outcome	probability	post-measurement state	final state of B
0	$\frac{1}{2}$	$ 00\rangle$	$ 0\rangle$
1	$\frac{1}{2}$	$ 11\rangle$	$ 1\rangle$

Suppose qubit B is subsequently measured in $\{|b_0\rangle, |b_1\rangle\}$. If B is in the state $|0\rangle$, we can write $|0\rangle = c_0 |b_0\rangle + c_1 |b_1\rangle$, and $p_{|0\rangle}(i) = |c_i|^2 = |\langle b_i | 0 \rangle|^2$. If B is in the state $|1\rangle$, we write $|1\rangle = d_0 |b_0\rangle + d_1 |b_1\rangle$, and $p_{|1\rangle}(i) = |d_i|^2 = |\langle b_i | 1 \rangle|^2$. Therefore, $p(i) = \frac{1}{2} |\langle b_i | 0 \rangle|^2 + \frac{1}{2} |\langle b_i | 1 \rangle|^2 = \frac{1}{2}$. The two outcomes for this measurement are equally likely, regardless of the choice of complete orthonormal basis $\{|b_0\rangle, |b_1\rangle\}$.

Suppose instead A is not measured, but we perform the same measurement on B . The initial state is $|\phi_{AB}^+\rangle$, so by the extended Born rule, $p(i) = \langle \phi_{AB}^+ | (I_A \otimes |b_i\rangle\langle b_i|) | \phi_{AB}^+ \rangle = \frac{1}{2}$. We can therefore not detect through measuring B whether a measurement was performed at A . This is the no-signalling principle.

We now prove the more general case. Let $|\phi_{AB}\rangle \in \mathcal{V}_A \otimes \mathcal{V}_B$ be an arbitrary possibly entangled state.

Suppose we measure B in a complete orthonormal basis $\{|b\rangle\}_{b=1}^{\dim \mathcal{V}_B}$, which is a complete projective measurement on B . Let $\{|a\rangle\}_{a=1}^{\dim \mathcal{V}_A}$ be a complete orthonormal basis for \mathcal{V}_A . Then, expanding $|\phi_{AB}\rangle$, in this basis, we can write $|\phi_{AB}\rangle = \sum_{a,b} c_{ab} |a\rangle |b\rangle$. We obtain outcome b with probability $p(b) = \langle \phi_{AB} | (I_A \otimes P_b) | \phi_{AB} \rangle = \sum_{a=1}^{\dim \mathcal{V}_A} |c_{ab}|^2$. The post-measurement state is $|\phi'_{AB}\rangle$.

Suppose that we first measure A in a complete orthonormal basis $\{|a\rangle\}_{a=1}^{\dim \mathcal{V}_A}$, and then perform the measurement $\{|b\rangle\}_{b=1}^{\dim \mathcal{V}_B}$ on B . The outcome of the first measurement is a with probability $p(a) = \langle \phi_{AB} | (P_a \otimes I_B) | \phi_{AB} \rangle = \sum_{b=1}^{\dim \mathcal{V}_B} |c_{ab}|^2$. We denote the post-measurement state of the joint system by $|\phi''_{AB}\rangle = \frac{(P_a \otimes I_B) |\phi_{AB}\rangle}{\sqrt{p(a)}}$. Then, the outcome of the second measurement is b with probability

$$\begin{aligned} p(a | b) &= \langle \phi''_{AB} | (I_A \otimes P_b) | \phi''_{AB} \rangle \\ &= \frac{1}{p(a)} \langle \phi_{AB} | (P_a \otimes I_B) (I_A \otimes P_b) (P_a \otimes I_B) | \phi_{AB} \rangle \\ &= \frac{1}{p(a)} \langle \phi_{AB} | (P_a \otimes P_b) | \phi_{AB} \rangle \\ p(a, b) &= p(a) p(a | b) = \langle \phi_{AB} | (P_a \otimes P_b) | \phi_{AB} \rangle = |c_{ab}|^2 \end{aligned}$$

Hence $p(b) = \sum_{a=1}^{\dim \mathcal{V}_A} |c_{ab}|^2$, which is exactly the distribution we obtained when no measurement on A was performed. This proves the no-signalling principle.

2.5 The Bell basis

Let $\mathbb{C}^2 \otimes \mathbb{C}^2$ model a quantum system representing the spins of two electrons. Consider $|\phi_{AB}^{\pm}\rangle = \frac{1}{\sqrt{2}}(|00\rangle + |11\rangle) \in \mathbb{C}^2 \otimes \mathbb{C}^2$. This is a *maximally entangled state*; we have information about the whole system, but no information about the individual states.

$$|\phi_{AB}^{\pm}\rangle = \frac{1}{\sqrt{2}}(|00\rangle \pm |11\rangle); \quad |\psi_{AB}^{\pm}\rangle = \frac{1}{\sqrt{2}}(|01\rangle \pm |10\rangle)$$

$\{|\phi_{AB}^{\pm}\rangle, |\psi_{AB}^{\pm}\rangle\}$ forms a complete orthonormal basis of $\mathbb{C}^2 \otimes \mathbb{C}^2$. This is called the *Bell basis*. The basis vectors are sometimes known as *EPR states*, after Einstein, Podolsky, and Rosen.

One bit of classical information can be encoded in a single qubit, and two bits can be encoded in a pair of qubits in the Bell basis. The Bell states have a *parity* 0 or 1, representing parallel $\{|\phi^{\pm}\rangle\}$ or antiparallel $\{|\psi^{\pm}\rangle\}$ spins. The states also have a *phase*, which can be positive $\{|\phi^+\rangle, |\psi^+\rangle\}$ or negative $\{|\phi^-\rangle, |\psi^-\rangle\}$. For example, we can encode the classical message 01 using the state $|\phi^-\rangle$.

We can perform a complete projective measurement on both qubits in the Bell basis to recover the encoded information with certainty. For instance, $P_{00} = |\phi^+\rangle\langle\phi^+|$. If we prepare a pair of electrons $|\phi\rangle$ in the state $|\phi^-\rangle$ for example, we obtain $p(00) = p(10) = p(11) = 0$ and $p(01) = 1$.

2.6 Superdense coding

Suppose Alice wants to send a classical message to Bob. Two bits of classical information can be sent reliably via a single qubit, provided that Alice and Bob share an entangled state, using *superdense*

coding or quantum dense coding. Let

$$X = \sigma_x; \quad Z = \sigma_z; \quad Y = i\sigma_y = \begin{pmatrix} 0 & 1 \\ -1 & 0 \end{pmatrix}$$

One can check that the Bell basis vectors satisfy

$$\begin{aligned} |\phi^+\rangle &= (I \otimes I) |\phi^+\rangle = (I \otimes I) |\phi^+\rangle \\ |\phi^-\rangle &= (Z \otimes I) |\phi^+\rangle = (I \otimes Z) |\phi^+\rangle \\ |\psi^+\rangle &= (X \otimes I) |\phi^+\rangle = (I \otimes X) |\phi^+\rangle \\ |\psi^-\rangle &= (Y \otimes I) |\phi^+\rangle = -(I \otimes Y) |\phi^+\rangle \end{aligned}$$

Suppose we have shared the entangled Bell state $|\phi_{AB}^+\rangle$ between Alice and Bob. The superdense coding protocol is

Alice's message	local action on A	final state of AB
00	I	$ \phi^+\rangle$
01	Z	$ \phi^-\rangle$
10	X	$ \psi^+\rangle$
11	Y	$ \psi^-\rangle$

Then, Alice sends qubit A to Bob, so Bob has the entire state AB . Bob performs a Bell measurement, which distinguishes between the four Bell states, thus recovering Alice's message. Since the state is maximally entangled, an eavesdropper who may intercept Alice's transmission cannot recover any part of the message.

2.7 Quantum gates

A quantum gate is given by a unitary operator acting on some qubits. Such gates have matrix representations in the computational basis.

(i) The *Hadamard gate* is

$$H = \frac{1}{\sqrt{2}} \begin{pmatrix} 1 & 1 \\ 1 & -1 \end{pmatrix}$$

One can show that

$$H|0\rangle = |+\rangle; \quad H|1\rangle = |-\rangle; \quad H|+\rangle = |0\rangle; \quad H|-\rangle = |1\rangle$$

Note that $H^\dagger = H^{-1} = H$ and $H^2 = I$. As an orthogonal transformation in \mathbb{R}^2 , it acts as a reflection by an angle of $\frac{\pi}{8}$ to the positive x axis. This gate is drawn

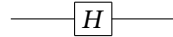

In general, by linearity we obtain

$$a|0\rangle + b|1\rangle \text{ --- } \boxed{H} \text{ --- } a|+\rangle + b|-\rangle$$

(ii) The X, Z gates are given by

$$X|k\rangle = |k \oplus 1\rangle; \quad Z|k\rangle = (-1)^k |k\rangle$$

where \oplus denotes addition modulo 2. They X, Z, Y gates are drawn



(iii) The *phase gate* is

$$P_\theta = \begin{pmatrix} 1 & 0 \\ 0 & e^{i\theta} \end{pmatrix}$$

Note that $Z = P_\pi$.

(iv) The *controlled-X gate*, also called a *CNOT gate*, is

$$CX = \begin{pmatrix} 1 & 0 & 0 & 0 \\ 0 & 1 & 0 & 0 \\ 0 & 0 & 0 & 1 \\ 0 & 0 & 1 & 0 \end{pmatrix} = \begin{pmatrix} I & 0 \\ 0 & X \end{pmatrix}$$

Note that $CX|i\rangle|j\rangle = |i\rangle|i \oplus j\rangle$. The first qubit is called the *control* qubit, and the second is called the *target* qubit. If $i = 0$, there is no action on the second qubit. If $i = 1$, X is performed on the second qubit. In general, $CX|0\rangle|\psi\rangle = |0\rangle|\psi\rangle$, and $CX|1\rangle|\psi\rangle = |1\rangle(X|\psi\rangle)$. The circuit diagram is as follows.

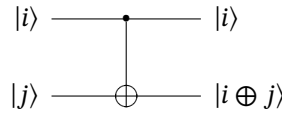

One can show that

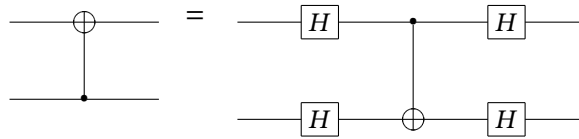

(v) The *controlled-Z gate*, also called a *CZ gate*, is

$$CZ = \begin{pmatrix} I & 0 \\ 0 & Z \end{pmatrix}$$

So $CZ|0\rangle|\psi\rangle = |0\rangle|\psi\rangle$ and $CZ|1\rangle|\psi\rangle = |1\rangle(Z|\psi\rangle)$. CZ is symmetric in its action on the two qubits; for example, $CZ_{12}|0\rangle|1\rangle = CZ_{21}|0\rangle|1\rangle$. This gate is drawn

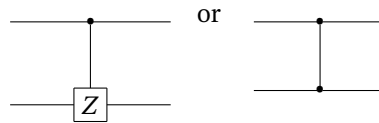

2.8 Quantum teleportation

Suppose Alice and Bob share the Bell state $|\phi^+\rangle_{AB}$, and that Alice wants to send the state of qubit $|\psi\rangle_C$ to Bob, but only classical communication between them is possible. It is possible to transfer the information about the state of $|\psi\rangle_C$ without physically transferring qubit C to Bob. This state transfer can be accomplished in such a way that is unaffected by any physical process in the space between Alice and Bob, since it relies only on classical communication.

The initial state of CAB is $|\Psi\rangle = |\psi\rangle_C \otimes |\phi^+\rangle_{AB}$, assuming $|\psi\rangle_C$ is uncorrelated with $|\phi^+\rangle_{AB}$. Let $|\psi\rangle_C = a|0\rangle_C + b|1\rangle_C$, so

$$|\Psi\rangle = |\psi\rangle_C \otimes |\phi^+\rangle_{AB} = \frac{1}{\sqrt{2}}[a|000\rangle + a|011\rangle + b|100\rangle + b|111\rangle]$$

Alice sends C and A through a CX gate. Now,

$$|\Psi\rangle = |\varphi_1\rangle = \frac{1}{\sqrt{2}}[a|000\rangle + a|011\rangle + b|110\rangle + b|101\rangle]$$

She now sends C through a Hadamard gate.

$$\begin{aligned} |\Psi\rangle = |\varphi_2\rangle &= \frac{1}{\sqrt{2}}[a|+00\rangle + a|+11\rangle + b|-10\rangle + b|-01\rangle] \\ &= \frac{1}{2} [|00\rangle|\psi\rangle + |01\rangle(X|\psi\rangle) + |10\rangle(Z|\psi\rangle) + |11\rangle(-Y|\psi\rangle)] \end{aligned}$$

Alice now measures CA in the computational basis of $\mathbb{C}^2 \otimes \mathbb{C}^2$. The probability of each outcome is $\frac{1}{4}$, irrespective of the values of a and b and hence of $|\psi\rangle$. She then sends the result of her measurement to Bob. If Alice measures outcome ij , B is in state $X^j Z^i |\psi\rangle$. Then, Bob can act on B using $Z^i X^j$, as X and Z are involutive, giving $|\psi\rangle$ as desired. This process can be represented with the following diagram, where double-struck wires are classical, and the meter symbol denotes a measurement of the quantum state.

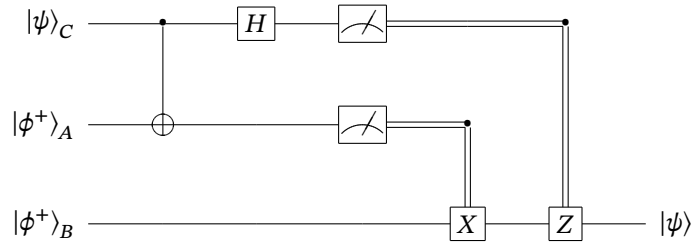

Note that after the measurement of CA , the entanglement between CA and B is broken. No-cloning is not violated, as the original state $|\psi\rangle_C$ is destroyed.

Note that the first steps of this process including Alice's measurement correspond to performing a Bell measurement on CA . This is because the action of CX_{CA} then H_C corresponds to a rotation of the Bell basis to the standard basis.

3 Quantum cryptography

3.1 One-time pads

We can use quantum information theory to securely transmit messages between agents Alice and Bob, who may be in distant locations, without the possibility that an eavesdropper Eve can recover the message that was sent.

We will assume that Alice and Bob have an authenticated classical channel through which they can send classical information; Alice and Bob can verify that any particular message on the channel came from a particular sender. We also assume that Eve cannot block the channel or modify any messages

transmitted, but she can monitor the channel freely. Hence, Alice and Bob can receive messages from each other without error.

In the classical setting, there exists a provably secure classical scheme for private communications, called the *one-time pad*. This requires that Alice and Bob share a private key K , which is a binary string. K must have been created beforehand, and must be chosen uniformly at random from the set of binary strings of the same length as the message M . Suppose $M, K \in \{0, 1\}^n$.

The protocol is as follows. First, Alice computes the encrypted message $C = M \oplus K$. She then sends C to Bob through the classical channel. Bob can then compute $C \oplus K = M \oplus K \oplus K = M$ to obtain the message that was sent by Alice. Eve cannot learn any information about the message (apart from its length), as she has no knowledge of K . In general, the probability that a particular K was chosen is 2^{-n} . This scheme cannot be broken.

Suppose that Alice and Bob use the same key K to send two messages M_1, M_2 . Eve can obtain $M_1 \oplus K$ and $M_2 \oplus K$, and can therefore compute $(M_1 \oplus K) \oplus (M_2 \oplus K) = M_1 \oplus M_2$, which gives some information about the messages that were sent. Any key must only be used once, so the one-time pad protocol is inefficient. To solve this problem, we will construct methods for distributing keys, using techniques from quantum information theory.

3.2 The BB84 protocol

Quantum key distribution allows Alice and Bob to generate a private key without needing to physically meet. This key can then be used to send messages over the one-time pad protocol. In addition to a classical channel, we assume that Alice and Bob also have access to a quantum channel through which they can send qubits. We will show that Eve cannot gain information about the key that Alice and Bob generate without being detected.

Consider the bases $\mathcal{B}_0 = \{|0\rangle, |1\rangle\}$, $\mathcal{B}_1 = \{|+\rangle, |-\rangle\}$. These are examples of *mutually unbiased bases*; a pair of bases such that if any basis vector is measured relative to the other basis, all outcomes are equally likely. For example, measuring $|+\rangle$ relative to \mathcal{B}_0 gives probability $\frac{1}{2}$ for outcomes 0 and 1.

First, Alice generates two m -bit strings $x = x_1 \dots x_m \in \{0, 1\}^m$, $y = y_1 \dots y_m \in \{0, 1\}^m$ uniformly at random. She then prepares the m -qubit state $|\psi_{xy}\rangle = |\psi_{x_1 y_1}\rangle \otimes \dots \otimes |\psi_{x_m y_m}\rangle$ where

$$|\psi_{x_i y_i}\rangle = \begin{cases} |0\rangle & x_i = 0; y_i = 0 \\ |1\rangle & x_i = 1; y_i = 0 \\ |+\rangle & x_i = 0; y_i = 1 \\ |-\rangle & x_i = 1; y_i = 1 \end{cases}$$

Alice sends the qubits $|\psi_{xy}\rangle$ to Bob with m uses of the quantum channel. The qubits received are not necessarily in the state $|\psi_{xy}\rangle$ due to noise or malicious manipulation of the channel. Bob then generates an m -bit string $y' = y'_1 \dots y'_m \in \{0, 1\}^m$ uniformly at random. If $y'_i = 0$, he measures the i th qubit in the basis $\mathcal{B}_0 = \{|0\rangle, |1\rangle\}$. If $y'_i = 1$, he acts on the i th qubit by the Hadamard gate and then measures in \mathcal{B}_0 . Equivalently, he measures the i th qubit in the basis $\mathcal{B}_1 = \{|+\rangle, |-\rangle\}$. Let the sequence of outcomes be $x' = x'_1 \dots x'_m \in \{0, 1\}^m$.

If $y'_i = y_i$, we have $x'_i = x_i$. Indeed, suppose $y'_i = 0 = y_i$. Then $|\pi_{x_i y_i}\rangle \in \mathcal{B}_0$, and Bob measures in basis \mathcal{B}_0 , so he can determine x_i with probability 1. If $y'_i = 1 = y_i$, $|\pi_{x_i y_i}\rangle \in \mathcal{B}_1$, and Bob measures in basis \mathcal{B}_1 .

Now, Alice and Bob compare their values of y and y' over the classical channel, and discard all x_i and x'_i for which $y_i \neq y'_i$. The remaining x_i and x'_i match, given that Bob receives $|\psi_{xy}\rangle$ exactly, and this forms the shared private key $\tilde{x} = \tilde{x}'$. The average length of \tilde{x} is $\frac{m}{2}$.

In the case $m = 8$, suppose $x = 01110100$ and $y = 11010001$. Alice prepares $|\psi_{xy}\rangle$ and sends the qubits to Bob. Suppose that Bob receives $|\psi_{xy}\rangle$ exactly, and he generates $y' = 01110110$. Bob measures qubit 1 in the basis \mathcal{B}_0 , but the qubit is in state $|+\rangle$, so he obtains both outcomes for x'_1 with equal probability. He measures qubit 2 in the basis \mathcal{B}_1 , and the qubit is in state $|-\rangle$, so after applying H and measuring, he obtains the correct outcome $x'_2 = 1$ with probability 1. After discarding mismatched y_i , the obtained private key is $\tilde{x} = 110$.

In the general case, however, there may be noise or malicious activity on the channel. We therefore include the further step of *information reconciliation* at the end of the BB84 protocol. Alice and Bob want to estimate the *bit error rate*, which is the proportion of bits in \tilde{x} and \tilde{x}' that differ. They can publicly compare a random sample of their bits, and discard the bits used in the test. They assume that the bit error rate in the sample is approximately the same as the bit error rate of \tilde{x} and \tilde{x}' .

Suppose that Alice and Bob have estimated the bit error rate to be $\frac{1}{7}$, and now have strings a, b of length 7. They can use classical error correcting code techniques to fix any remaining errors. They publicly agree to act on a, b by a matrix

$$\tilde{H} = \begin{pmatrix} 0 & 0 & 0 & 1 & 1 & 1 & 1 \\ 0 & 1 & 1 & 0 & 0 & 1 & 1 \\ 1 & 0 & 1 & 0 & 1 & 0 & 1 \end{pmatrix}$$

which is the check matrix of a Hamming code. Alice computes the *syndrome* for a , given by $s^A = (s_1^A, s_2^A, s_3^A)^T = \tilde{H}a^T$, and sends this to Bob on the public channel. Bob computes the syndrome s^B for b , and calculates $s = s^B - s^A$. There is a unique bit string v with at most one nonzero entry such that $\tilde{H}v^T = s$; he can therefore recover a .

The estimation of the bit error rate and the transmission of the syndrome can reveal some information on the public channel. Alice and Bob want to estimate the maximum amount of information that an eavesdropper could gain about the remaining bits, using *privacy amplification*. This depends on the choice of action that Eve takes.

As an example, suppose $a^* = (a_1, a_2, a_3) \in \{0, 1\}^3$, and suppose Eve knows at most one bit of this string. Let $c = (a_1 \oplus a_3, a_2 \oplus a_3)$. We claim that Eve has no knowledge about c . Indeed, we can explicitly enumerate all possibilities of a^* and the corresponding values of c , and show that Eve's knowledge about any of the bits of a^* does not change the distribution of c .

One strategy for Eve, called the *intercept and resend* strategy, is to intercept the qubits as they are transferred to Bob, measure them, and retransmit the post-measurement state. The best possible measurement she can perform is in the *Breidbart basis* $\{|\alpha_0\rangle, |\alpha_1\rangle\}$ where

$$|\alpha_0\rangle = \cos \frac{\pi}{8} |0\rangle - \sin \frac{\pi}{8} |1\rangle; \quad |\alpha_1\rangle = \sin \frac{\pi}{8} |0\rangle + \cos \frac{\pi}{8} |1\rangle$$

Note that

$$|\langle \alpha_0 | 0 \rangle|^2 = |\langle \alpha_0 | + \rangle|^2 = \cos^2 \frac{\pi}{8}; \quad |\langle \alpha_1 | 1 \rangle|^2 = |\langle \alpha_1 | - \rangle|^2 = \cos^2 \frac{\pi}{8}$$

The $|\alpha_i\rangle$ provide the best possible simultaneous approximations of $|0\rangle, |+\rangle$ and $|1\rangle, |-\rangle$. Suppose $y'_i = y_i$, and suppose Eve intercepts the i th qubit and measures it in the Breidbart basis. Her outcomes are

0 or 1, and she learns the correct value of x_i with probability $\cos^2 \frac{\pi}{8} \approx 0.85$. If she measures 0, she transmits $|\alpha_0\rangle$ to Bob, and if she measures 1, she transmits $|\alpha_1\rangle$ to Bob.

The probability that Bob makes an incorrect inference of the value of the i th bit after this manipulation is $\frac{1}{4}$, regardless of the state of the qubit transmitted by Alice. Suppose $|\psi_{x_i, y_i}\rangle = |0\rangle$, so $x_i = 0, y_i = 0$. Then,

$$\begin{aligned} \mathbb{P}(x'_i \neq x_i) &= \mathbb{P}(B \text{ measures } 1 \mid A \text{ sent } |0\rangle) \\ &= \mathbb{P}(E \text{ sent } |\alpha_0\rangle \mid A \text{ sent } |0\rangle) \mathbb{P}(B \text{ measures } 1 \mid E \text{ sent } |\alpha_0\rangle) \\ &\quad + \mathbb{P}(E \text{ sent } |\alpha_1\rangle \mid A \text{ sent } |0\rangle) \mathbb{P}(B \text{ measures } 1 \mid E \text{ sent } |\alpha_1\rangle) \\ &= |\langle \alpha_0 | 0 \rangle|^2 |\langle \alpha_0 | 1 \rangle|^2 + |\langle \alpha_1 | 0 \rangle|^2 |\langle \alpha_1 | 1 \rangle|^2 \\ &= \frac{1}{4} \end{aligned}$$

4 Quantum computation

4.1 Classical computation

A *computational task* takes an input bit string and produces an output bit string.

A decision problem is a computational task that produces an output of length 1. Let $B = B_1 = \{0, 1\}$ and denote $B_n = \{0, 1\}^n$. Define $B^* = \bigcup_{n \geq 1} B_n$. A *language* is a subset $L \subseteq B^*$. A decision problem corresponds to the problem of checking whether a word $w \in B^*$ lies in a language L . For example, the set of primes, expressed in binary, forms a language $P \subseteq B^*$, and there is a corresponding decision problem to check if a given binary string represents a prime.

More generally, the output of a computational task can be of any length. For example, the task $\text{FACTOR}(x)$ takes the input x and produces a bit string containing a factor of x , or 1 if x is prime.

There are various models of computation, but we restrict to the *circuit* or *gate array* model. In this model, we have an input $x = b_1 \dots b_n \in B_n$, and extend it with some trailing zeroes to add scratch space to perform computations. We then perform some computational steps, an application of designated Boolean gates $f : B_n \rightarrow B_m$ on preassigned bits. For each n , we have a circuit C_n , which is a prescribed sequence of computational steps that performs a given task for all inputs of size n . The output to the computation is a designated subsequence of the extended bit string.

Suppose that, in addition to extending the input bit string with zeroes, we also add k random bits, which have values set to 0 or 1 uniformly at random. The output of the computation will now be probabilistic. The probability that the output is y is $a2^{-k}$, where a is the number of bit strings r that produce the desired outcome. We typically require that the output is correct with some prescribed probability.

4.2 Classical complexity

The *time complexity* is a measure of the amount of computational steps required for a particular algorithm for an input of size n . In the circuit model, we define $T(n)$ to be the total number of gates in the circuit C_n , known as the *size* of the circuit or *runtime* of the algorithm.

For a positive function $T(n)$, we write $T(n) = O(f(n))$ if there exist positive constants c, n_0 such that for all $n > n_0$, we have $T(n) \leq cf(n)$. If $T(n) = O(n^k)$ for some $k > 0$, we say that $T(n)$ is $O(\text{poly}(n))$, and the corresponding algorithm is a *poly-time* algorithm. The class of languages for

which the membership problem has a classical poly-time algorithm is called P. The class of languages for which the membership problem has a randomised classical poly-time algorithm that gives the correct answer with probability at least $\frac{2}{3}$ is called BPP, short for *bounded-error probabilistic poly-time*. The problem FACTOR(M, N) which determines if there is a nontrivial factor of N that is at most M does not lie in BPP. The best known runtime is $T(n) = O\left(n^{\frac{1}{3}}(\log n)^{\frac{2}{3}}\right)$.

A black box promise problem is a computational task where the input is a *black box* or *oracle* which can compute a Boolean function $f : B_m \rightarrow B_n$, and there is an *a priori promise* on f restricting the possible values of f . For example, the black box promise problem for constant vs. balanced functions takes a function $f : B_n \rightarrow B$ such that f is constant or *balanced*, in which case f is equal to zero for exactly half of the 2^n possible inputs.

The corresponding complexity is called *query complexity*, which counts the amount of times we need to query the black box. We typically wish to minimise the query complexity.

4.3 Quantum circuits

In a quantum circuit, we have qubit inputs $|b_1\rangle \dots |b_n\rangle |0\rangle \dots |0\rangle$ analogously to the classical case. The input size n is the number of qubits. The addition of randomness to classical computation needs no analogue in the quantum case, since randomness is obtained by measurement. For instance, if we have a qubit $|0\rangle$, we can generate a uniform Bernoulli random variable by sending the qubit through a Hadamard gate and then measuring in the computational basis.

The computational steps are gates or unitary operators, which act on a prescribed set of qubits, constituting a quantum circuit C_n . The output is obtained by performing a measurement on a prescribed set of qubits. One can show that any circuit involving arbitrarily many measurements is equivalent to a circuit that only performs a single measurement at the end of the computation.

4.4 Quantum oracles

Note that all quantum gates are invertible, as they are represented with unitary operators, but not all classical gates are invertible. Any $f : B_m \rightarrow B_n$ can be expressed in an equivalent invertible form $\tilde{f} : B_{m+n} \rightarrow B_{m+n}$ by defining $\tilde{f}(b, c) = (b, c \oplus f(b))$. If we can compute f we can also compute \tilde{f} , and conversely given \tilde{f} we can find $f(b) = \tilde{f}(b, 0)$. This is self-inverse.

$$\tilde{f}(\tilde{f}(b, c)) = \tilde{f}(b, c \oplus f(b)) = (b, c \oplus f(b) \oplus f(b)) = (b, c)$$

A quantum oracle for a function $f : B_m \rightarrow B_n$ is the quantum gate U_f acting on $m+n$ qubits such that $U_f |x\rangle |y\rangle = |x\rangle |y \oplus f(x)\rangle$ for $|x\rangle, |y\rangle$ states in the computational basis. In other words, its action on the computational basis is \tilde{f} . We say that $|x\rangle$ is the *input register* and $|y\rangle$ is the *output register*.

One can show that U_f is always a unitary operator. We can show this directly by considering $U_f |x'\rangle |y'\rangle = |x'\rangle |y' \oplus f(x')\rangle$, and we can take the inner product with $U_f |x\rangle |y\rangle = |x\rangle |y \oplus f(x)\rangle$. An easier way to show this is to consider $\tilde{f} : B_k \rightarrow B_k$ as a permutation on B_k where $m+n = k$. We can write $U_f |x\rangle |y\rangle = U_f |i_1 \dots i_k\rangle = |\tilde{f}(i_1 \dots i_k)\rangle$. Since \tilde{f} is a permutation, U_f is therefore represented by a permutation matrix, which has a single 1 in each row and column. All permutation matrices are unitary.

In contrast to a classical oracle, a quantum oracle can act on a superposition of input registers. Let

$f : B_m \rightarrow B_n$, and consider the *equal superposition* state $|\varphi_m\rangle = \frac{1}{\sqrt{2^m}} \sum_{x \in B_m} |x\rangle$. We can find

$$U_f |\varphi_m\rangle |y\rangle = U_f \left(\frac{1}{\sqrt{2^m}} \sum_{x \in B_m} |x\rangle \right) |y\rangle = \frac{1}{\sqrt{2^m}} \sum_{x \in B_m} U_f |x\rangle |y\rangle = |\psi_f\rangle$$

In a single use of the oracle, we obtain a final state which depends on the value of f corresponding to all possible inputs. One can easily create such an equal superposition state $|\varphi_m\rangle$ by sending the m -qubit state $|0\rangle \dots |0\rangle$ through m Hadamard gates $H \otimes \dots \otimes H$. We have $(H|0\rangle)^{\otimes m} = (|+\rangle)^{\otimes m} = |\varphi_m\rangle$. This creates a superposition of exponentially many terms using a linear amount of Hadamard gates.

4.5 Deutsch–Jozsa algorithm

Consider the black box problem for balanced vs. constant functions. Classically, one needs $2^{n-1} + 1$ queries to solve the problem in the worst case. This amount of queries is clearly sufficient; even if f is balanced, the first 2^{n-1} queries could have equal outcomes, but the subsequent query must have a different outcome. Suppose that there exists an algorithm that can solve the problem in 2^{n-1} queries. An adversary that controls the oracle can respond with 0 for every query, and subsequently choose a function f that agrees with the earlier query results but is balanced or constant as required to cause the algorithm to produce an error. Therefore, classically we require a query complexity of $O(\exp(n))$.

Suppose we have a quantum oracle U_f with $U_f |x\rangle |y\rangle = |x\rangle |y \oplus f(x)\rangle$, where $|x\rangle$ is an n -qubit state and $|y\rangle$ is a 1-qubit state. Set each qubit to state $|0\rangle$, then act by $H^{\otimes n} \otimes (H \cdot X)$ on $|x\rangle |y\rangle$. We then obtain the state $|A\rangle = \frac{1}{\sqrt{2^n}} \sum_{x \in B_n} |x\rangle |-\rangle$. Send this state through the oracle to obtain $U_f |A\rangle = \frac{1}{\sqrt{2^n}} U_f \sum_{x \in B_n} |x\rangle |-\rangle$. Note that

$$\begin{aligned} U_f |x\rangle |-\rangle &= \frac{1}{\sqrt{2}} U_f (|x\rangle |0\rangle - |x\rangle |1\rangle) \\ &= \frac{1}{\sqrt{2}} (|x\rangle |f(x)\rangle - |x\rangle |f(x)^c\rangle) \\ &= \begin{cases} \frac{1}{\sqrt{2}} |x\rangle (|0\rangle - |1\rangle) = |x\rangle |-\rangle & \text{if } f(x) = 0 \\ \frac{1}{\sqrt{2}} |x\rangle (|1\rangle - |0\rangle) = -|x\rangle |-\rangle & \text{if } f(x) = 1 \end{cases} \\ &= (-1)^{f(x)} |x\rangle |-\rangle \end{aligned}$$

The method of encoding all information into a phase is called *phase kickback*. Hence,

$$U_f |A\rangle = \frac{1}{\sqrt{2^n}} U_f \sum_{x \in B_n} |x\rangle |-\rangle = \frac{1}{\sqrt{2^n}} \left(\sum_{x \in B_n} (-1)^{f(x)} |x\rangle \right) |-\rangle$$

We can then easily discard the last qubit, as it is now in a product state. We obtain

$$|f\rangle = \frac{1}{\sqrt{2^n}} \sum_{x \in B_n} (-1)^{f(x)} |x\rangle$$

If f is constant,

$$|f\rangle = \pm \frac{1}{\sqrt{2^n}} \sum_{x \in B_n} |x\rangle = \pm (H|0\rangle)^{\otimes n}$$

If we apply $H^{\otimes n}$ to $|f\rangle$, we obtain $\pm |0\rangle^{\otimes n}$. If f is balanced, writing $|\varphi_n\rangle = \frac{1}{\sqrt{2^n}} \sum_{y \in B_n} |y\rangle$,

$$\langle f|\varphi_n\rangle = \frac{1}{2^n} \sum_{x,y \in B_n} (-1)^{f(x)} \langle y|x\rangle = \frac{1}{2^n} \sum_{x \in B_n} (-1)^{f(x)} = 0$$

In this case, $|f\rangle$ is orthogonal to $|\varphi_n\rangle$. Applying $H^{\otimes n}$ to $|f\rangle$, we have that $H^{\otimes n}|f\rangle$ is orthogonal to $H^{\otimes n}|\varphi_n\rangle = |0\rangle^{\otimes n}$.

After obtaining $|f\rangle$, we apply $H^{\otimes n}$ and measure in the computational basis. If f is constant, we measure $0 \dots 0$ with probability 1, and if f is balanced, we measure $0 \dots 0$ with probability 0. This allows us to infer whether f is constant or balanced with probability 1.

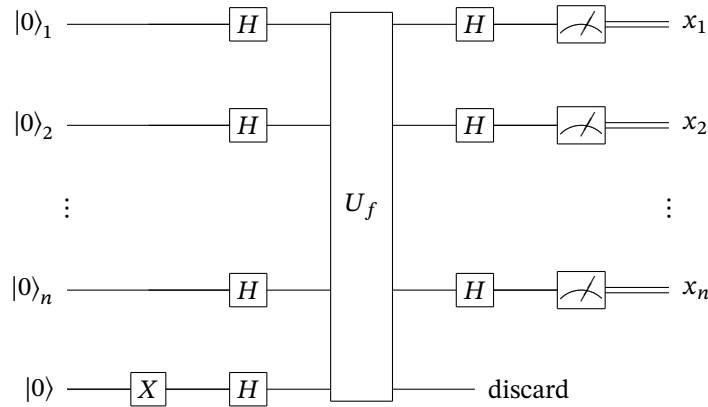

For this algorithm, we use one query and $3n + 2$ further operations.

Suppose we permit a probability $\varepsilon > 0$ of error. In the quantum case, we only need one query. In the classical case, there is a randomised algorithm which solves the problem with a constant number $O(\log \frac{1}{\varepsilon})$ of queries for all n . Choose k inputs each chosen uniformly at random, and evaluate $f(x)$ for each x in this set. If $f(x)$ is constant for all of these k inputs, we infer f is constant; otherwise we infer it is balanced. An error can only occur when the function is balanced but we infer it is constant. The probability of error is $\frac{2}{2^k} = 2^{-k+1}$. Hence, we can take $\varepsilon < 2^{-k+1}$, so $k = O(\log \frac{1}{\varepsilon})$.

4.6 Simon's algorithm

Consider a function $f : B_n \rightarrow B_n$ with the promise that either f is injective, or $f(x) = f(y)$ if and only if $y = x$ or $y = x \oplus \xi$ for a fixed $0 \neq \xi \in B_n$. The problem is to determine with bounded error whether f is in the 1-1 form or the 2-1 form, and in the latter case, to find the constant ξ . Note that $f(x \oplus \xi) = f(x)$ is the statement that f has period ξ .

Classically, the query complexity is $O(\exp(n))$. In order to solve the problem, we need to find two distinct x, y inputs for which $f(x) = f(y)$, or show that this is not possible. However, there is a quantum algorithm with query complexity $O(n)$.

4.7 Quantum Fourier transform

Let \mathcal{V}_N be a state space, and $\mathcal{B}_N = \{|0\rangle, |1\rangle, \dots, |N-1\rangle\}$ be an orthonormal basis for \mathcal{V}_N . Write \mathbb{Z}_N for integers modulo N , and let $\omega = e^{\frac{2\pi i}{N}}$. For $|k\rangle \in \mathcal{B}_N$, we define

$$QFT_N |k\rangle = \frac{1}{\sqrt{N}} \sum_{\ell=0}^{N-1} e^{\frac{2\pi i}{N} k\ell} |\ell\rangle = \frac{1}{\sqrt{N}} \sum_{\ell=0}^{N-1} \omega^{k\ell} |\ell\rangle$$

The quantum Fourier transform can be viewed as a generalisation of the Hadamard operator, as $QFT_2 = H$.

We show that this is a unitary operator.

$$(QFT)_{jk} = \langle j | QFT | k \rangle = \frac{1}{\sqrt{N}} \sum_{\ell=0}^{N-1} \omega^{k\ell} \langle j | \ell \rangle = \frac{1}{\sqrt{N}} \omega^{jk}$$

$$QFT = \frac{1}{\sqrt{N}} \begin{pmatrix} 1 & 1 & 1 & 1 & \dots \\ 1 & \omega & \omega^2 & \omega^3 & \dots \\ 1 & \omega^2 & \omega^4 & \omega^6 & \dots \\ 1 & \omega^3 & \omega^6 & \omega^9 & \dots \\ \vdots & \vdots & \vdots & \vdots & \ddots \end{pmatrix}$$

Let S_j be the sum of the j th row or column. If $j = 0$, $S_j = \frac{1}{\sqrt{N}}N$. Otherwise,

$$S_j = \frac{1}{\sqrt{N}}(1 + \omega^j + \dots + \omega^{j(N-1)}) = \frac{1}{\sqrt{N}} \cdot \frac{1 - \omega^{jN}}{1 - \omega^j} = 0$$

We can use this to prove that $(QFT^\dagger QFT)_{jk} = \delta_{jk}$, so it is a unitary operator.

Suppose we have a periodic function $f : \mathbb{Z}_N \rightarrow Y$, where typically $Y = \mathbb{Z}_M$ for some M . Let r be the smallest integer in \mathbb{Z}_N for which $f(x+r) = f(x)$ for all $x \in \mathbb{Z}_N$, so f is periodic with period r . Suppose further that f is injective in each period. We wish to find r with a particular probability of error.

There is a classical algorithm with query complexity $O(\sqrt{N}) = O(2^{\log N \frac{1}{2}}) = O(2^{\frac{1}{2} \log N})$. In the quantum case, for any error probability $\varepsilon \in (0, 1)$, there is an algorithm with query complexity $O(\log \log N)$, which provides an exponential speed increase.

We first describe an attempt to construct such an algorithm without using the quantum Fourier transform. Begin with the uniform superposition state $|\psi_N\rangle = \frac{1}{\sqrt{N}} \sum_{x=0}^{N-1} |x\rangle$. Consider the quantum oracle U_f corresponding to $f : \mathbb{Z}_N \rightarrow \mathbb{Z}_M$, defined by $U_f |x\rangle |y\rangle = |x\rangle |y + f(x)\rangle$, where addition is performed modulo M . Set the output register $|y\rangle$ to $|0\rangle$, and then compute $|f\rangle = U_f |\psi_N\rangle |0\rangle$. We obtain

$$|f\rangle = U_f |\psi_N\rangle |0\rangle = \frac{1}{\sqrt{N}} \sum_{x=0}^{N-1} U_f |x\rangle |0\rangle = \frac{1}{\sqrt{N}} \sum_{x=0}^{N-1} |x\rangle |f(x)\rangle$$

Since r is the period, we have $r \mid N$, so let $A = \frac{N}{r} \in \mathbb{N}$ be the number of periods. We now measure the second register, giving an outcome $y = f(x_0)$ for some $x_0 \in \{0, \dots, r-1\}$. Note that $y = f(x_0 + jr)$

for any $j \in \{0, \dots, A-1\}$. The terms in $|f\rangle$ which contribute to the outcome $y = f(x_0)$ are

$$\frac{1}{\sqrt{N}} \sum_{j=0}^{A-1} |x_0 + jr\rangle |f(x_0)\rangle$$

Hence, the probability of obtaining a particular outcome $f(x_0)$ is $\frac{A}{N} = \frac{1}{r}$. Then, the post-measurement state of the input register is

$$|\text{per}\rangle = \frac{1}{\sqrt{A}} \sum_{j=0}^{A-1} |x_0 + jr\rangle$$

The state $|\text{per}\rangle$ is periodic. If we measure the input register, we obtain $|x_0 + j_0r\rangle$ for some $j_0 \in \{0, \dots, A-1\}$, selected uniformly at random. The probability that the outcome of this second measurement is $x_0 + j_0r$ is $\frac{1}{A}$. Therefore, no information about r is obtained.

We resolve this issue by utilising the quantum Fourier transform. Instead of measuring the input register, we act on $|\text{per}\rangle$ by QFT_N . Since

$$QFT_N |x\rangle = \frac{1}{\sqrt{N}} \sum_{y=0}^{N-1} \omega^{xy} |y\rangle$$

we find

$$\begin{aligned} QFT_N |\text{per}\rangle &= \frac{1}{\sqrt{A}} \sum_{j=0}^{A-1} QFT_N |x_0 + jr\rangle \\ &= \frac{1}{\sqrt{A}} \frac{1}{\sqrt{N}} \sum_{j=0}^{A-1} \sum_{y=0}^{N-1} \omega^{(x_0+jr)y} |y\rangle \\ &= \frac{1}{\sqrt{NA}} \sum_{y=0}^{N-1} \omega^{x_0 y} \underbrace{\left[\sum_{j=0}^{A-1} (\omega^{ry})^j \right]}_S |y\rangle \end{aligned}$$

Note that

$$S = \begin{cases} A & \text{if } \omega^{ry} = 1 \\ \frac{1-\omega^{ryA}}{1-\omega^{ry}} = 0 & \text{otherwise} \end{cases}$$

Note that $\omega^{ry} = 1$ if $y = kA = \frac{kN}{r}$ for $k \in \{0, \dots, r-1\}$. Hence, we obtain

$$QFT_N |\text{per}\rangle = \frac{A}{\sqrt{NA}} \sum_{k=0}^{r-1} \omega^{x_0 \frac{kN}{r}} \left| \frac{kN}{r} \right\rangle = \frac{1}{\sqrt{r}} \sum_{k=0}^{r-1} \omega^{x_0 \frac{kN}{r}} \left| \frac{kN}{r} \right\rangle$$

The value of x_0 is no longer present in a ket, and has been converted into phase information. It therefore does not affect measurement outcomes. The periodicity in r has been inverted into periodicity in $\frac{1}{r}$. The resulting state is still periodic, but each period begins at 0 instead of x_0 .

Now, when measuring this register, the outcome is $c = \frac{k_0N}{r}$ for some $k_0 \in \{0, \dots, r-1\}$. Each outcome occurs with probability $\frac{1}{r}$. Note that $\frac{k_0}{r} = \frac{c}{N}$, and $\frac{c}{N}$ is known after performing the measurement; we wish to know the value of r .

Suppose first that k_0 is coprime to r . In this case, we can cancel $\frac{c}{N}$ to its lowest form, then the denominator is r . If k_0 is not coprime to r , the denominator \tilde{r} will instead be a factor of r . To solve this, we can compute the reduced denominator and then evaluate $f(0), f(\tilde{r})$; if they are equal, $\tilde{r} = r$, and otherwise, $\tilde{r} \mid r$. We would like to know the probability that a randomly chosen k_0 is coprime to the true periodicity r .

Theorem (coprimality theorem). Let $\varphi(r)$ denote the number of integers less than r that are coprime to r . Then there exist $c > 0, r_0 > 0$ such that for all $r \geq r_0$, $\varphi(r) \geq c \frac{r}{\log \log r}$. In particular, $\varphi(r) = \Omega\left(\frac{r}{\log \log r}\right)$.

This theorem implies that since k_0 is chosen uniformly at random, the probability that k_0 is coprime to r is $O\left(\frac{1}{\log \log r}\right)$. We claim that if we repeat this process $O(\log \log r)$ times, we will obtain an outcome c such that after cancellation, $\frac{c}{N} = \frac{k_0}{r}$ where k_0 is coprime to r in at least one case, with a constant probability. This claim follows from the following lemma.

Lemma. Suppose that a single trial has success probability p , and the trial is repeated M times independently, for any $\varepsilon \in (0, 1)$, the probability of at least one success is greater than $1 - \varepsilon$ if $M = \frac{-\log \varepsilon}{p}$.

Therefore, to achieve a constant probability $1 - \varepsilon$ of success, we need $O\left(\frac{1}{p}\right)$ trials. In the algorithm above, $p = O\left(\frac{1}{\log \log r}\right)$, so we need $O(p) = O(\log \log r) < O(\log \log N)$ trials to achieve the desired result.

In each invocation of the algorithm, we query f three times: once to construct the state $|f\rangle$, and twice to check if \tilde{r} is the true periodicity. We also need to apply the quantum Fourier transform QFT_N , which has implementations in $O((\log N)^2)$ steps. We must also perform standard arithmetic operations such as to cancel denominators, which are computable in $O(\text{poly}(\log N))$ steps. Therefore, we succeed in determining the period with any constant probability of success $1 - \varepsilon$ with $O(\log \log N)$ queries and $O(\text{poly}(\log N))$ additional steps.

4.8 Efficient implementation of quantum Fourier transform

We can implement a quantum Fourier transform using $O(\text{poly}(\log N))$ gates if $N = 2^n$. In this case, QFT_N acts on n qubits. If $N \neq 2^n$, we do not have an efficient implementation; in this case, we approximate N by 2^k for some $k \in \mathbb{Z}$. In the case $N = 2^n$, we demonstrate a quantum circuit of size $O(n^2)$.

If $x \in \mathbb{Z}_n = \{0, \dots, 2^n - 1\}$, note that

$$QFT_N |x\rangle = \frac{1}{\sqrt{N}} \sum_{y=0}^{N-1} \omega^{xy} |y\rangle$$

We can represent x and y by n -bit strings.

$$x = (x_0, x_1, \dots, x_{n-1}); \quad x = \sum_{i=0}^{n-1} 2^i x_i$$

Now, $\omega^{xy} = \exp\left[\frac{2\pi i}{2^n} xy\right]$.

$$\frac{xy}{2^n} = \frac{1}{2^n} [(x_0 + 2x_1 + \dots + 2^{n-1}x_{n-1})(y_0 + 2y_1 + \dots + 2^{n-1}y_{n-1})]$$

Retaining only the fractional terms of $\frac{xy}{2^n}$, as integral parts do not contribute to the final result, we obtain

$$y_{n-1}(.x_0) + y_{n-2}(.x_1x_0) + \dots + y_0(.x_{n-1} \dots x_0)$$

where for instance $.x_1x_0 = \frac{x_1}{2} + \frac{x_0}{2^2}$. Hence,

$$\begin{aligned} QFT |x\rangle &= \frac{1}{\sqrt{2^n}} \sum_{y_0, \dots, y_{n-1} \in \{0,1\}} \exp\left[\frac{2\pi i xy}{2^n}\right] |y_{n-1}\rangle \dots |y_0\rangle \\ &= \left(\frac{1}{\sqrt{2}} \sum_{y_{n-1} \in \{0,1\}} \exp[2\pi i y_{n-1}(.x_0)] |y_{n-1}\rangle\right) \dots \left(\frac{1}{\sqrt{2}} \sum_{y_0 \in \{0,1\}} \exp[2\pi i y_0(.x_{n-1} \dots x_0)] |y_0\rangle\right) \\ &= \frac{1}{\sqrt{2}} (|0\rangle + e^{2\pi i(.x_0)} |1\rangle) \dots \frac{1}{\sqrt{2}} (|0\rangle + e^{2\pi i(.x_{n-1} \dots x_0)} |1\rangle) \end{aligned}$$

To implement the quantum Fourier transform, we will use the Hadamard gate, the 1-qubit phase gate, and the 2-qubit controlled phase gate. Note that we can write

$$H |x\rangle = \frac{1}{\sqrt{2}} [|0\rangle + e^{2\pi i(.x)} |1\rangle]$$

For any $d \in \mathbb{Z}_+$, the phase gate is given by

$$R_d = \begin{pmatrix} 1 & 0 \\ 0 & \exp\left[\frac{i\pi}{2^d}\right] \end{pmatrix} = \begin{pmatrix} 1 & 0 \\ 0 & \exp\left[2\pi i(. \underbrace{0 \dots 0}_d 1)\right] \end{pmatrix}$$

Note that $R_d |0\rangle = |0\rangle$ and $R_d |1\rangle = e^{2\pi i(.0 \dots 01)} |1\rangle$. In the case $d = 1$, we obtain $R_1 |1\rangle = e^{2\pi i(.01)} |1\rangle = i |1\rangle$. The two-qubit controlled phase gate, denoted CR_d , is drawn

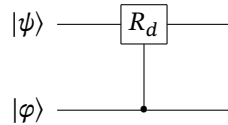

If $|\varphi\rangle = |0\rangle$, $CR_d |0\rangle |\psi\rangle = |0\rangle |\psi\rangle$. If $|\varphi\rangle = |1\rangle$, $CR_d |1\rangle |\psi\rangle = |1\rangle R_d |\psi\rangle$. We will now describe the quantum circuit for QFT_8 , so $N = 8$ and $n = 3$.

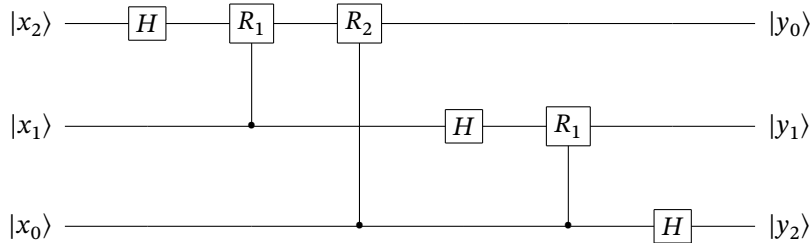

Applying the given gates to $|x_2\rangle$, we obtain

$$\begin{aligned}
|x_2\rangle &\xrightarrow{H} \frac{1}{\sqrt{2}}[|0\rangle + e^{2\pi i(\cdot x_2)} |1\rangle] \\
&\xrightarrow{R_1} \frac{1}{\sqrt{2}}[|0\rangle + e^{2\pi i(\cdot x_2)} e^{2\pi i(0x_1)} |1\rangle] \\
&\xrightarrow{R_2} \frac{1}{\sqrt{2}}[|0\rangle + e^{2\pi i(\cdot x_2)} e^{2\pi i(0x_1)} e^{2\pi i(00x_0)} |1\rangle] \\
&= \frac{1}{\sqrt{2}}[|0\rangle + e^{2\pi i(\cdot x_2 x_1 x_0)} |1\rangle] = |y_0\rangle
\end{aligned}$$

as required. Typically, after applying the above circuit, we will swap the states $|y_0\rangle, |y_1\rangle, |y_2\rangle$ to be in reverse order; this takes $O(n)$ gates.

In this implementation, we used 3 Hadamard gates, and $2 + 1 = 3$ controlled phase gates. If $N = 2^n$, we need n Hadamard gates and $\frac{n(n-1)}{2} = O(n^2)$ controlled phase gates.

4.9 Grover's algorithm

Suppose we have a large unstructured database of N items, in which we aim to locate a particular 'good' item. Suppose that given an item, we can easily check if it is the 'good' item. We wish to construct an algorithm to locate this good item with success probability at least $1 - \varepsilon$. Each access to the database is considered a query.

In the classical case, we need $O(N)$ queries: if we find a bad item, it gives us no information about the location of the good item. The probability that any item is good is $\frac{1}{N}$. Given M queries, the probability of success is $\frac{M}{N} \geq 1 - \varepsilon$, so $M \geq (1 - \varepsilon)N$ gives $M = O(N)$. In the quantum case, $O(\sqrt{N})$ queries are necessary and sufficient. This is not an exponential speedup but a quadratic speedup.

Let \mathcal{V} be a vector space, and let $|v\rangle \in \mathcal{V}$. We define the rank 1 projection operator $\Pi_{|\alpha\rangle} = |\alpha\rangle\langle\alpha|$, and the reflection operator $I_{|\alpha\rangle} = I - 2|\alpha\rangle\langle\alpha|$. Note that $I_{|\alpha\rangle}|\alpha\rangle = -|\alpha\rangle$. Let $|\psi\rangle \in \mathcal{S}_{|v\rangle}^\perp = \text{span}\{|\beta\rangle \in \mathcal{V} \mid \langle\alpha|\beta\rangle = 0\}$. Then $I_{|\alpha\rangle}|\psi\rangle = |\psi\rangle - |\alpha\rangle\langle\alpha|\psi\rangle = |\psi\rangle$.

For any unitary operator U acting on \mathcal{V} , we have $U\Pi_{|\alpha\rangle}U^\dagger = U|\alpha\rangle\langle\alpha|U^\dagger = \Pi_{U|\alpha\rangle}$. Note also that $UI_{|\alpha\rangle}U^\dagger = U(I - 2|\alpha\rangle\langle\alpha|)U^\dagger = I - 2|U\alpha\rangle\langle U\alpha| = I_{U|\alpha\rangle}$.

If $\mathcal{V} = \mathbb{C}^2$, for all $|\alpha\rangle \in \mathcal{V}$, let $|\alpha^\perp\rangle$ be orthogonal to $|\alpha\rangle$. For all $|v\rangle \in \mathcal{V}$, we can write $|v\rangle = a|\alpha\rangle + b|\alpha^\perp\rangle$, so $\Pi_{|\alpha\rangle}|v\rangle = a|\alpha\rangle$ and $I_{|\alpha\rangle}|v\rangle = -a|\alpha\rangle + b|\alpha^\perp\rangle$.

Let $N = 2^n$, so we can label each item in the database with an n -bit binary string. We will convert the search problem into a black-box promise problem. The database corresponds to the Boolean function $f: B_n \rightarrow B$ where $f(x_0) = 1$ for a particular $x_0 \in B_n$, and $f(x) = 0$ otherwise. The corresponding quantum oracle is $U_f|x\rangle|y\rangle = |x\rangle|y \oplus f(x)\rangle$, where $|x\rangle \in (\mathbb{C}^2)^{\otimes n}$ and $|y\rangle \in \mathbb{C}^2$. The fact that the database is unstructured corresponds to the fact that the quantum oracle U_f is a black box. We will use the operator I_{x_0} , which has the following action on the basis vectors.

$$I_{x_0}|x\rangle = \begin{cases} +|x\rangle & \text{if } x \neq x_0 \\ -|x\rangle & \text{if } x = x_0 \end{cases}$$

If $x_0 = 0 \dots 0 \in B_n$, we define $I_0 = I_{x_0}$. Note that I_{x_0} can be implemented using U_f ; indeed,

$$\begin{aligned} U_f |x\rangle |-\rangle &= \frac{1}{\sqrt{2}} U_f |x\rangle (|0\rangle - |1\rangle) \\ &= \frac{1}{\sqrt{2}} (|x\rangle |f(x)\rangle - |x\rangle |f(x)^c\rangle) \\ &= \begin{cases} \frac{1}{\sqrt{2}} |x\rangle (|0\rangle - |1\rangle) & \text{if } x \neq x_0 \\ \frac{1}{\sqrt{2}} |x\rangle (|1\rangle - |0\rangle) & \text{if } x = x_0 \end{cases} \\ &= \begin{cases} +|x\rangle |-\rangle & \text{if } x \neq x_0 \\ -|x\rangle |-\rangle & \text{if } x = x_0 \end{cases} \end{aligned}$$

Hence, $U_f |x\rangle |-\rangle = (I_{x_0} |x\rangle) |-\rangle$. So if $|\psi\rangle \in (\mathbb{C}^2)^{\otimes n}$, $|\psi\rangle = a_0 |x_0\rangle + \sum_{x \neq x_0} a_x |x\rangle$ gives $U_f |\psi\rangle |-\rangle = (I_{x_0} |\psi\rangle) |-\rangle = -a_0 |x_0\rangle + \sum_{x \neq x_0} a_x |x\rangle$.

Given a black box which computes I_{x_0} for some $x_0 \in B_n$, we wish to determine x_0 with the least amount of queries. We will now describe Grover's algorithm. We begin with the equal superposition state $|\psi_0\rangle = \frac{1}{\sqrt{2^n}} \sum_{x \in B_n} |x\rangle$. Consider *Grover's iteration operator* $Q = -H_n I_0 H_n I_{x_0}$ where $H_n = H^{\otimes n}$. Note that Q is real-valued, so acts geometrically on the real-valued vector $|\psi_0\rangle$ in real Euclidean space. It has the following properties.

- (i) In the plane $\mathcal{P}(x_0)$ spanned by $|x_0\rangle$ and $|\psi_0\rangle$, Q acts as a rotation through an angle 2α where $\sin \alpha = \frac{1}{\sqrt{2^n}}$.
- (ii) In the plane orthogonal to $\mathcal{P}(x_0)$, Q acts as $-I$.

We repeatedly apply Q to $|\psi_0\rangle$ to obtain the rotated vector $|\psi'_0\rangle$, and then measure in the computational basis.

$$|\psi'_0\rangle = a_0 |x_0\rangle + \sum_{x_i \neq x_0} \sum a_i |x_i\rangle$$

Hence, the probability that the outcome is x_0 is $|a_0|^2 = |\langle x_0 | \psi'_0 \rangle|^2 = |\cos \delta|^2 \approx 1$ where δ is the angle between $|\psi'_0\rangle$ and $|x_0\rangle$.

If n is large, $|\psi_0\rangle$ is almost orthogonal to $|x_0\rangle$, with $\langle x_0 | \psi_0 \rangle = \frac{1}{\sqrt{2^n}} = \cos \beta$. By property (i), Q acting on $|\psi_0\rangle$ rotates the state by 2α , where $\sin \alpha = \frac{1}{\sqrt{2^n}}$. Let m be the number of iterations needed to rotate $|\psi_0\rangle$ close to $|x_0\rangle$. Then

$$m = \frac{\beta}{2\alpha} = \frac{\arccos\left(\frac{1}{\sqrt{2^n}}\right)}{2 \arcsin\left(\frac{1}{\sqrt{2^n}}\right)}$$

Since $\sin \alpha \approx \alpha$, this implies that $2\alpha \approx 2 \sin \alpha = \frac{2}{\sqrt{2^n}}$. Then $2\alpha m \approx \frac{\pi}{2}$, so $m \approx \frac{\pi}{4\alpha} = \frac{\pi}{4} \sqrt{N}$. The number of iterations is independent of $|x_0\rangle$; it depends only on n .

Example. Consider a database with four items, so $n = 2, N = 4$. Here, $\sin \alpha = \frac{1}{2}$, so $\alpha = \frac{\pi}{6}$. Q causes a rotation through $2\alpha = \frac{\pi}{3}$. The initial state is

$$|\psi_0\rangle = |++\rangle = \frac{1}{2}(|00\rangle + |01\rangle + |10\rangle + |11\rangle)$$

For any $x_0 \in B_2$, we have $\cos \beta = \langle x_0 | \psi_0 \rangle = \frac{1}{2}$ so $\beta = \frac{\pi}{3}$. Therefore, we need precisely one iteration, which rotates $|\psi_0\rangle$ to $|x_0\rangle$ exactly. Performing a measurement in the computational basis, we obtain x_0 with certainty.

We now prove the geometric properties of Q . First, note that $Q = -H_n I_0 H_n I_{x_0} = -I_{|\psi_0\rangle} I_{|x_0\rangle}$. If $|\alpha\rangle, |v\rangle \in \mathcal{V}$ and $|v\rangle \in \mathcal{P}(x_0)$, we have

- $I_{|x_0\rangle} |v\rangle = |v\rangle - 2\langle x_0 | v \rangle |x_0\rangle$;
- $I_{|\psi_0\rangle} |v\rangle = |v\rangle - 2\langle \psi_0 | v \rangle |\psi_0\rangle$.

These operators are reflections about lines perpendicular to $|x_0\rangle$ and $|\psi_0\rangle$ respectively. Thus, $\mathcal{P}(x_0)$ is stable under the action of $I_{|x_0\rangle}$ and $I_{|\psi_0\rangle}$.

Let M_1, M_2 be lines in the Euclidean plane, intersecting at O . Let θ be the angle between M_1 and M_2 . Then, reflection about M_1 then M_2 acts as an anticlockwise rotation by 2θ about O .

In our case, the angle between the lines perpendicular to $|x_0\rangle$ and $|\psi_0\rangle$ is β . Therefore, $I_{|\psi_0\rangle} I_{|x_0\rangle}$ is an anticlockwise rotation by an angle of 2β . For any real unit vector $v \in \mathbb{R}^2$, we have $-I_v = I_{v^\perp}$ where v^\perp is a unit vector orthogonal to v . Hence, $-I_{|\psi_0\rangle} I_{|x_0\rangle} = I_{|\psi_0^\perp\rangle} I_{|x_0\rangle}$, which is an anticlockwise rotation by an angle of 2α , as $\alpha + \beta = \frac{\pi}{2}$. This proves property (i).

Now consider $|\xi\rangle \in \mathcal{P}(x_0)^\perp$ perpendicular to $|\psi_0\rangle$ and to $|x_0\rangle$. Clearly $I_{|x_0\rangle} |\xi\rangle = |\xi\rangle$ and $I_{|\psi_0\rangle} |\xi\rangle = |\xi\rangle$. So $Q |\xi\rangle = -|\xi\rangle$, giving property (ii).

Grover's algorithm achieves an unstructured search for a unique good item in approximately $\frac{\pi}{4}\sqrt{N}$ queries, and there is no algorithm that has smaller asymptotic query complexity. Any quantum algorithm that achieves this search in an unstructured database of size N must use $O(\sqrt{N})$ queries. Moreover, it can be shown that $\frac{\pi}{4}(1 - \varepsilon)\sqrt{N}$ queries are insufficient for each ε , so Grover's algorithm is tight.

4.10 Grover's algorithm for multiple items

Consider the case where there are $r \geq 1$ good items, and r is known. Here, $f(x_i) = 1$ if $i = 1, \dots, r$, and $f(x) = 0$ otherwise, where x_1, \dots, x_r are the binary labels for the good items. We want to find any of the good items. Then, define

$$I_G |x\rangle = I - 2 \sum_{i=1}^r |x_i\rangle \langle x_i| = \begin{cases} +|x\rangle & x \notin \{x_1, \dots, x_r\} \\ -|x\rangle & x \in \{x_1, \dots, x_r\} \end{cases}$$

Note that I_G is not of the form $I_{|v\rangle}$ for a single vector $|v\rangle$. Now, define $Q_G = -H_n I_0 H_n I_G = -I_{|\psi_0\rangle} I_G$. Let $|\psi_G\rangle = \frac{1}{\sqrt{r}} \sum_{i=1}^r |x_i\rangle$ be an equal superposition of the good states, and $|\psi_B\rangle = \frac{1}{\sqrt{N-r}} \sum_{i=r+1}^N |x_i\rangle$ be an equal superposition of the bad states. Note that $\langle \psi_G | \psi_B \rangle = 0$. Begin with the equal superposition state.

$$|\psi_0\rangle = (H |0\rangle)^{\otimes N} = \frac{\sqrt{r}}{\sqrt{N}} |\psi_G\rangle + \frac{\sqrt{N-r}}{\sqrt{N}} |\psi_B\rangle$$

Consider the plane \mathcal{P}_G spanned by $|\psi_G\rangle$ and $|\psi_0\rangle$, which contains $|\psi_B\rangle$. Let α be the angle between $|\psi_G\rangle$ and $|\psi_0^\perp\rangle$.

We show that in the plane \mathcal{P}_G , Q_G acts as a rotation through an angle 2α where $\sin \alpha = \langle \psi_0 | \psi_G \rangle = \frac{\sqrt{r}}{\sqrt{N}}$. The states $|\psi_G\rangle, |\psi_B\rangle$ form an orthonormal basis for \mathcal{P}_G . We find $I_G(a|\psi_G\rangle + b|\psi_B\rangle) = -a|\psi_G\rangle +$

$b|\psi_B\rangle$; indeed, restricting to the plane \mathcal{P}_G , the action of I_G is precisely the action of $I_{|\psi_G\rangle}$. Hence, as before, Q_G causes the desired rotation through 2α in this plane. The probability of finding a single good item is $|\langle\psi|\psi_G\rangle|^2$, as $|\psi\rangle = a|\psi_G\rangle + b|\psi_B\rangle$.

Suppose now that r is unknown. In this case, we start with $|\psi_0\rangle$ and repeatedly apply Q to rotate $|\psi_0\rangle$ to $|\psi_G\rangle$ as before. However, we do not know how many iterations of Q to apply, since this depends on r .

If $r \ll N$, we choose K uniformly at random in $(0, \frac{\pi}{4}\sqrt{N})$, and apply K iterations of Q . We measure the final state $|\psi^K\rangle$ to obtain x , and check if $f(x) = 1$ or not. Note that each iteration causes a rotation of 2α where $\sin \alpha = \frac{\sqrt{r}}{\sqrt{N}}$ so $2\alpha \approx 2\frac{\sqrt{r}}{\sqrt{N}}$. Choosing K therefore implicitly chooses a random angle in the range $(0, \frac{\pi}{2}\sqrt{r})$. Now, if the final rotated state $|\psi\rangle$ makes an angle within $\pm\frac{\pi}{4}$ with $|\psi_0\rangle$, the probability of locating a good item is $|\langle\psi|\psi_0\rangle|^2 \geq \cos^2\frac{\pi}{4} = \frac{1}{2}$. Since for every quadrant in the plane \mathcal{P}_G , half of the angles are within $\pm\frac{\pi}{4}$ from the y -axis, the randomised procedure using $O(\sqrt{N})$ queries will locate a good item with probability approximately $\frac{1}{4}$. The procedure can then be repeated to reduce the error probability to an acceptable level.

4.11 NP problems

A verifier V for a language L is a computation with two inputs w, c such that

- (i) if $w \in L$, there exists a *certificate of membership* c such that $V(w, c)$ halts in an accepting state; and
- (ii) if $w \notin L$, for any c , $V(w, c)$ halts in a rejecting state.

V is a *poly-time* verifier if for all inputs w, c , the algorithm V runs in polynomial time in n , where n is the size of the input w . A problem in the *non-deterministic polynomial-time* complexity class NP is easy to verify, but may be hard to solve. More precisely, a language L is in NP if it has a polynomial time verifier V .

Alternatively, consider a computer operating non-deterministically; at each binary choice, the computer duplicates itself and performs both branches in parallel. We require that all possible paths eventually halt with either an accepting or rejecting state. The running time of a given algorithm is the length of the longest path. The computation is defined to accept its input if at least one path accepts it, and rejects its input if all paths reject it. One can check that NP is precisely the class of languages that are decided by a non-deterministic computation with polynomial running time.

Let $f : B_n \rightarrow B$ be a Boolean formula. The *Boolean satisfiability problem* SAT seeks an assignment of the variables x_1, \dots, x_n such that $f(x_1, \dots, x_n) = 1$. Any such assignment is called a *satisfying assignment*. This problem clearly lies in NP; if f is satisfiable, then c is any assignment for which $V(f, c) = 1$ where $V(f, c) = f(c)$. Brute-force methods have $O(2^n)$ runtime.

Searching for arbitrarily many good items in an unstructured database corresponds to SAT. Assuming that there are few satisfying assignments, we can run the randomised Grover's algorithm to give a quantum algorithm for solving SAT in $O(\sqrt{2^n})$ time with low probability of error. Any NP problem can be converted into an application of SAT; we say SAT is *NP-complete*. Grover's algorithm can hence be applied to any NP problem to provide a quadratic speedup.

4.12 Shor's algorithm

Suppose N is a positive integer and $n = \lceil \log N \rceil$ is the number of bits in a binary representation of N . We wish to factorise N . We will describe an algorithm which, given N and a fixed acceptable probability of error, outputs a factor $1 < k < N$, or outputs N if N is prime. This algorithm runs in polynomial time in n ; there is no classical algorithm with this property.

We first use results from number theory to convert the problem into a periodicity determination problem. Then, we apply the quantum period-finding algorithm using the quantum Fourier transform.

Choose an integer $1 < a < N$ uniformly at random, and compute $b = \gcd(a, N)$. If $b > 1$, then $b \mid N$ so is a factor; in this case we simply output b . If $b = 1$, then a, N are coprime.

Theorem (Euler's theorem). Let a, N be coprime. Then there exists $1 < r < N$ such that $a^r \equiv 1 \pmod{N}$. A minimal such r is called the *order* of a modulo N .

Consider the *modular exponentiation function* $f: \mathbb{Z} \rightarrow \mathbb{Z}/N\mathbb{Z}$ such that $f(k) = a^k \pmod{N}$. This function satisfies $f(k_1 + k_2) = f(k_1)f(k_2)$. f is periodic with period r , and is injective within each period.

Suppose that we can find r , and suppose r is even. Then $a^r - 1 \equiv (a^{\frac{r}{2}} + 1)(a^{\frac{r}{2}} - 1) \equiv 0 \pmod{N}$. Note that $N \nmid (a^{\frac{r}{2}} - 1)$ since r was minimal such that $a^r \equiv 1 \pmod{N}$. If $N \nmid (a^{\frac{r}{2}} + 1)$, then N must have some prime factors in $(a^{\frac{r}{2}} + 1)$ and some in $(a^{\frac{r}{2}} - 1)$. We can use Euclid's algorithm to compute $\gcd(a^{\frac{r}{2}} + 1, N)$ and $\gcd(a^{\frac{r}{2}} - 1, N)$, which are factors of N . Thus, we find factors of N provided r is even and $a^{\frac{r}{2}} + 1 \not\equiv 0 \pmod{N}$.

Consider $N = 15, a = 7$. Then $f(k) = 7^k \pmod{15}$ takes values 1, 7, 4, 13, so has period $r = 4$. This is even, so we can write $a^r - 1 = (a^{\frac{r}{2}} + 1)(a^{\frac{r}{2}} - 1) = 50 \cdot 48$. $N = 15$ does not divide 50, so $\gcd(50, N) = 5$ is a factor, and $\gcd(48, 15) = 3$ is a factor.

Theorem. Let N be odd and not a prime power. Then, choosing a uniformly at random such that $\gcd(a, N) = 1$, the probability that r is even and $(a^{\frac{r}{2}} + 1) \not\equiv 0 \pmod{N}$ is at least $\frac{1}{2}$.

This implies that if N is odd and not a prime power, we obtain a factor of N with probability at least $\frac{1}{2}$. We repeat this process until the probability of not finding a factor is acceptably low. If N is even, we simply output 2 as a factor.

Lemma. Let $N = c^\ell$ for some $c, \ell \in \mathbb{N}$. There is a classical polynomial-time algorithm that computes c .

Shor's algorithm can be summarised as follows.

- (i) Test if N is even; if so, output 2 and halt.
- (ii) Run the classical algorithm to test if N is of the form c^ℓ with $\ell > 1$; if so, output c and halt.
- (iii) Choose $1 < a < N$ uniformly at random and compute $b = \gcd(a, N)$. If $b > 1$, output b and halt.

(iv) Find the period r of the modular exponentiation function $f(k) = a^k \bmod N$. If this fails, return to step (iii).

(v) If r is even and $(a^{\frac{r}{2}} + 1) \not\equiv 0 \pmod N$, compute $t = \gcd(a^{\frac{r}{2}} + 1, N)$; if $1 < t < N$, output t and halt. Otherwise, return to step (iii).

We now describe the method to compute the period of the modular exponentiation function. Note that $f: \mathbb{Z} \rightarrow \mathbb{Z}$, not $\mathbb{Z}_N \rightarrow \mathbb{Z}_M$; we therefore cannot directly use the algorithm discussed previously. We must first truncate the domain \mathbb{Z} to some \mathbb{Z}_M . If r is unknown, f will not necessarily be periodic on \mathbb{Z}_M . However, if M is $O(N^2)$, the single incomplete period has a negligible effect on the periodicity determination. We will define $M = 2^m$ for some m and use QFT_M .

Consider a finite domain $D = \{0, \dots, 2^m - 1\}$, where m is the smallest integer such that $2^m > N^2$. Suppose $2^m = Br + b$ where $0 \leq b < r$, so $B = \lfloor \frac{2^m}{r} \rfloor$. We start with the equal superposition state $|\psi_m\rangle = \frac{1}{\sqrt{2^m}} \sum_{x \in D} |x\rangle$. Consider the quantum oracle U_f corresponding to the modular exponentiation function f . Then

$$\begin{aligned} |\Psi\rangle &= U_f |\psi_m\rangle |0\rangle \\ &= \frac{1}{\sqrt{2^m}} \sum_{x \in D} |x\rangle |f(x)\rangle \\ &= \frac{1}{\sqrt{2^m}} \sum_{x_0=0}^{b-1} \sum_{j=0}^{B-1} |x_0 + jr\rangle |f(x_0)\rangle + \frac{1}{\sqrt{2^m}} \sum_{x_0=b}^r \sum_{j=0}^{B-1} |x_0 + jr\rangle |f(x_0)\rangle \end{aligned}$$

Measuring the second register, we obtain an outcome $y = f(x_0)$. In the case $x_0 < b$, $f(x_0) = f(x_0 + jr)$ for $j \in \{0, \dots, B\}$. If $x_0 \geq b$, $f(x_0) = f(x_0 + jr)$ for $j \in \{0, \dots, B-1\}$.

If $y = f(x_0)$ for $x_0 < b$, the probability of measuring y is $\frac{B+1}{2^m}$. The post-measurement state of the first register is $|\text{per}\rangle = \frac{1}{\sqrt{B+1}} \sum_{j=0}^B |x_0 + jr\rangle$. In the case $x_0 \geq b$, we have $|\text{per}\rangle = \frac{1}{\sqrt{B}} \sum_{j=0}^{B-1} |x_0 + jr\rangle$. In both cases,

$$|\text{per}\rangle = \frac{1}{\sqrt{A}} \sum_{j=0}^{A-1} |x_0 + jr\rangle$$

where $A = B + 1$ if $y = f(x_0)$ with $x_0 < b$ and $A = B$ if $y = f(x_0)$ with $x_0 \geq b$. We act on $|\text{per}\rangle$ by QFT_{2^m} to obtain

$$\begin{aligned} QFT_{2^m} |\text{per}\rangle &= \frac{1}{\sqrt{A}} \frac{1}{\sqrt{2^m}} \sum_{j=0}^{A-1} \sum_{c=0}^{2^m-1} \omega^{(x_0+jr)c} |c\rangle \\ &= \frac{1}{\sqrt{A}} \frac{1}{\sqrt{2^m}} \sum_{c=0}^{2^m-1} \omega^{x_0 c} \underbrace{\left[\sum_{j=0}^{A-1} (\omega^{cr})^j \right]}_S |c\rangle \end{aligned}$$

where $\omega = 2^{\frac{2\pi i}{M}}$ where $M = 2^m$. S is a geometric series. If $\frac{M}{r} \notin \mathbb{Z}$, $\alpha^A \neq 1$. We claim that a measurement on $QFT_{2^m} |\text{per}\rangle$ yields an integer c which is close to a multiple of $\frac{M}{r}$ with high probability.

Consider $k\frac{2^m}{r}$ for $k = 0, \dots, r-1$. Each of these multiples is within $\frac{1}{2}$ of a unique integer; indeed, $2^m = Br + b$ so $r < 2^m$, giving that $k\frac{2^m}{r}$ cannot be a half integer. Consider the values of c such that $|c - k\frac{2^m}{r}| < \frac{1}{2}$ for $k = 0, \dots, r-1$.

Theorem. Suppose that $QFT_{2^m} |\text{per}\rangle = \sum_{c=0}^{2^m-1} g(c) |c\rangle$, and that we measure the state and receive an outcome c . Let c_k be the unique integer such that $|c_k - k\frac{2^m}{r}| < \frac{1}{2}$. Then $\mathbb{P}(c = c_k) > \frac{\gamma}{r}$ for a fixed constant γ (which can be shown to be $\frac{4}{\pi^2}$). Moreover, the probability that k, r are coprime is $\Omega\left(\frac{1}{\log \log r}\right)$ by the coprimality theorem.

Thus, with $O(\log \log N) > O(\log \log r)$ repetitions, we obtain a good c value with high probability. Suppose that we measure c such that $|c - k\frac{2^m}{r}| < \frac{1}{2}$, so $|\frac{c}{2^m} - \frac{k}{r}| < \frac{1}{2^{m+1}}$. Recall that $r < N$ and m is minimal such that $2^m > N^2$. Then $|\frac{c}{2^m} - \frac{k}{r}| < \frac{1}{2N^2}$. Note that $\frac{c}{2^m}$ is known.

We show that there is at most one fraction $\frac{k}{r}$ with denominator $r < N$ such that $|\frac{c}{2^m} - \frac{k}{r}| < \frac{1}{2N^2}$. Suppose $\frac{k'}{r'}, \frac{k''}{r''}$ both satisfy this requirement. Then

$$\left| \frac{k'}{r'} - \frac{k''}{r''} \right| = \frac{|k'r'' - k''r'|}{r'r''} \geq \frac{1}{r'r''} > \frac{1}{N^2}$$

But $\left| \frac{c}{2^m} - \frac{k'}{r'} \right|, \left| \frac{c}{2^m} - \frac{k''}{r''} \right| < \frac{1}{2N^2}$, contradicting the triangle inequality. This result is the reason for choosing m minimal such that $2^m > N^2$. Therefore, we have with high probability that $\frac{c}{2^m}$ is close to a unique fraction $\frac{k}{r}$.

Example. Let $N = 39$ and choose $a = 7$; note that 7 and 39 are coprime. Let r be the period of $f(k) = a^k \bmod 39$. Note that $2^{10} < N^2 < 2^{11}$, so set $m = 11$. Suppose that $QFT_{2^{11}} |\text{per}\rangle$ gives a measurement of c . Then $|c - k\frac{2^{11}}{r}| < \frac{1}{2}$ with probability $\frac{\gamma}{r}$.

Suppose $c = 853$. One can explicitly check all fractions of the form $\frac{a}{b}$ to find one that satisfies $\left| \frac{a}{b} - \frac{853}{2048} \right| < \frac{1}{2^{12}}$. This is consistent with $\frac{a}{b} = \frac{5}{12}, \frac{10}{24}$; as we are constrained by coprimality we must choose $r = 12$. One can check that $7^{12} \equiv 1 \pmod{39}$, hence $r = 12$. Note that $O(N^2) = O(\exp(n))$ computations are needed for this calculation; there is a more efficient way to compute a, b using continued fractions.

A rational number $\frac{s}{t}$ can be written in the form of a continued fraction

$$\frac{s}{t} = \frac{1}{a_1 + \frac{1}{a_2 + \frac{1}{\dots + \frac{1}{a_\ell}}}} = [a_1, \dots, a_\ell]$$

where a_1, \dots, a_ℓ are positive integers. We can write $\frac{s}{t} = \frac{1}{\frac{t}{s}} = \frac{1}{a_1 + \frac{s_1}{t_1}}$, and so on. For example, if $\frac{s}{t} = \frac{13}{35}$, we can find $a_1 = 2, a_2 = 2, a_3 = 1, a_4 = 1, a_5 = 2$ and $\ell = 5$. Since the sequence t_k is decreasing, the

expansion will always terminate. For each $k = 1, \dots, \ell$, we can truncate the computation at level k . This gives the sequence of rational numbers

$$\frac{p_1}{q_1} = [a_1], \frac{p_2}{q_2} = [a_1, a_2], \dots, \frac{p_\ell}{q_\ell} = [a_1, \dots, a_\ell] = \frac{s}{t}$$

$\frac{p_k}{q_k}$ is the k th convergent of the continued fraction $\frac{s}{t}$.

Lemma. Let a_1, \dots, a_ℓ be positive reals, and let $p_0 = 0, q_0 = 1, p_1 = 1, q_1 = a_1$. Then,

- (i) $[a_1, \dots, a_k] = \frac{p_k}{q_k}$ where $p_k = a_k p_{k-1} + p_{k-2}$ and $q_k = a_k q_{k-1} + q_{k-2}$;
- (ii) if the a_k are integers, then so are the p_k and q_k , with $q_k p_{k-1} - p_k q_{k-1} = (-1)^k$ for $k \geq 1$, and moreover $\gcd(p_k, q_k) = 1$.

Theorem. Consider a continued fraction $\frac{s}{t} = [a_1, \dots, a_\ell]$, and let $\frac{p_k}{q_k}$ be the k th convergent.

If s and t are given by m -bit integers, then the length ℓ of the continued fraction is $O(m)$, and the continued fraction and its convergents can be computed in $O(m^3)$ time.

Proofsketch. We have $a_k \geq 1$ and $p_k, q_k \geq 1$. Part (i) of the above lemma implies that (p_k) and (q_k) are increasing sequences. If k is even, $p_k \geq 2p_{k-2}$ and $q_k \geq 2q_{k-2}$ hence $p_k, q_k \geq 2^{\frac{k}{2}}$. Thus, in general, $p_k, q_k \geq 2^{\lfloor \frac{k}{2} \rfloor}$. We therefore need at most $\ell = O(m)$ iterations to obtain $\frac{s}{t}$ exactly, since q_k, p_k are coprime and each are at least $2^{\lfloor \frac{k}{2} \rfloor}$. The computation of each successive a_k value involves division of $O(m)$ -bit integers and converting it into an integer and remainder term; these computations can be performed in $O(m^2)$ time. Hence, the entire computation requires only $O(m^3)$ time. \square

Theorem. Let $x \in \mathbb{Q}$ with $0 < x < 1$. Let $\frac{p}{q} \in \mathbb{Q}$ such that $|x - \frac{p}{q}| < \frac{1}{2q^2}$. Then $\frac{p}{q}$ is a convergent of the continued fraction expansion of x .

In our situation, we have c such that

$$\left| \frac{c}{2^m} - \frac{k}{r} \right| < \frac{1}{2N^2}; \quad r < N$$

In particular, $\left| \frac{c}{2^m} - \frac{k}{r} \right| < \frac{1}{2r^2}$, and we have seen that there is at most one fraction $\frac{k}{r}$ such that this holds. Note that $0 < c < 2^m$, so $0 < \frac{c}{2^m} < 1$. Hence, $\frac{k}{r}$ is a convergent of $\frac{c}{2^m}$. Note that $2^m > N^2 > 2^{m-1}$, so $c, 2^m$ are $O(m)$ -bit integers, and hence the sequence of convergents (and in particular $\frac{k}{r}$) can be computed in $O(m^3)$ time. We can then explicitly check for each convergent $\frac{k}{r}$ if $\left| \frac{c}{2^m} - \frac{k}{r} \right| < \frac{1}{2N^2}$ and $r < N$ hold.

Example. Consider again $N = 39$ and $2^m = 2^{11} = 2048$. Suppose $c = 853$. Then one can explicitly compute

$$\frac{c}{2^m} = \frac{853}{2048} = [2, 2, 2, 42, 4]$$

Its convergents are

$$\frac{1}{2}; \quad \frac{2}{5}; \quad \frac{5}{12}; \quad \frac{212}{509}; \quad \frac{853}{2048}$$

Only $\frac{5}{12}$ satisfies $\left| \frac{c}{2^m} - \frac{k}{r} \right| < \frac{1}{2N^2}$ and $r < N$. So $r = 12$ is the period.

A classical factoring algorithm takes $O\left(\exp\left(n^{\frac{1}{3}}\right)\right)$ time; we analyse the time complexity of Shor's algorithm. Consider the case when N is odd and not a prime power, and let $n = \log N$. The modular exponentiation function requires $O(m) = O(n)$ multiplications, each of which take $O(m^2) = O(n^2)$ time, so this algorithm takes $O(n^3)$ time. The construction of the equal superposition state requires $m = O(n)$ Hadamard gates, and applying the quantum oracle gives the state $\frac{1}{2^m} \sum_{x \in B_m} |x\rangle |f(x)\rangle$ in $O(n^3)$ steps. We measure the second register which contains $O(n)$ qubits, hence requiring $O(n)$ single-qubit measurements. The first register is then in state $|per\rangle$. We then apply the quantum Fourier transform QFT_{2^m} , which can be implemented in $O(m^2) = O(n^2)$ steps. We then measure the first register to obtain c , requiring $O(n)$ single-qubit measurements. Then, we find r from c using the continued fraction algorithm, requiring $O(n^3)$ steps. A good c value is obtained with probability $1 - \varepsilon$ with $O(\log \log N) = O(\log n)$ repetitions. Then, $t = \gcd(a^{\frac{r}{2}} + 1, N)$ is computed using Euclid's algorithm, taking $O(n^3)$ steps. If r is odd or is even but $t = 1$, then we return to the start, and the case where r is even and $t \neq 1$ occurs with probability at least $1 - \varepsilon$ if we perform $\log \frac{1}{\varepsilon}$ repetitions.